



Parallel Arm Closer TS 4204DABCSR

UK
CA

1354

01246 261 491 www.rutlanduk.co.uk

PRINT TO A3 PAPER SIZE FOR 1:1 SCALE

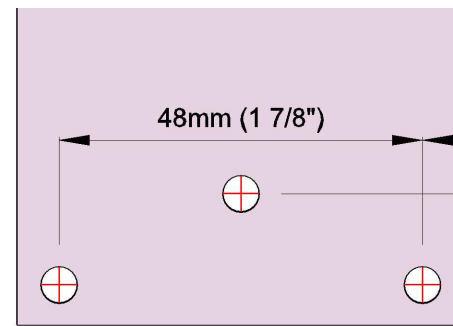

166mm (6 9/16")

FOLD 2

FOLD 1

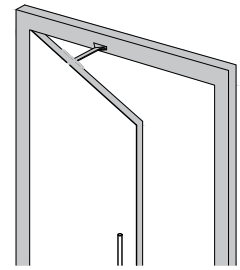

75mm (2 15/16")

19mm (3/4")

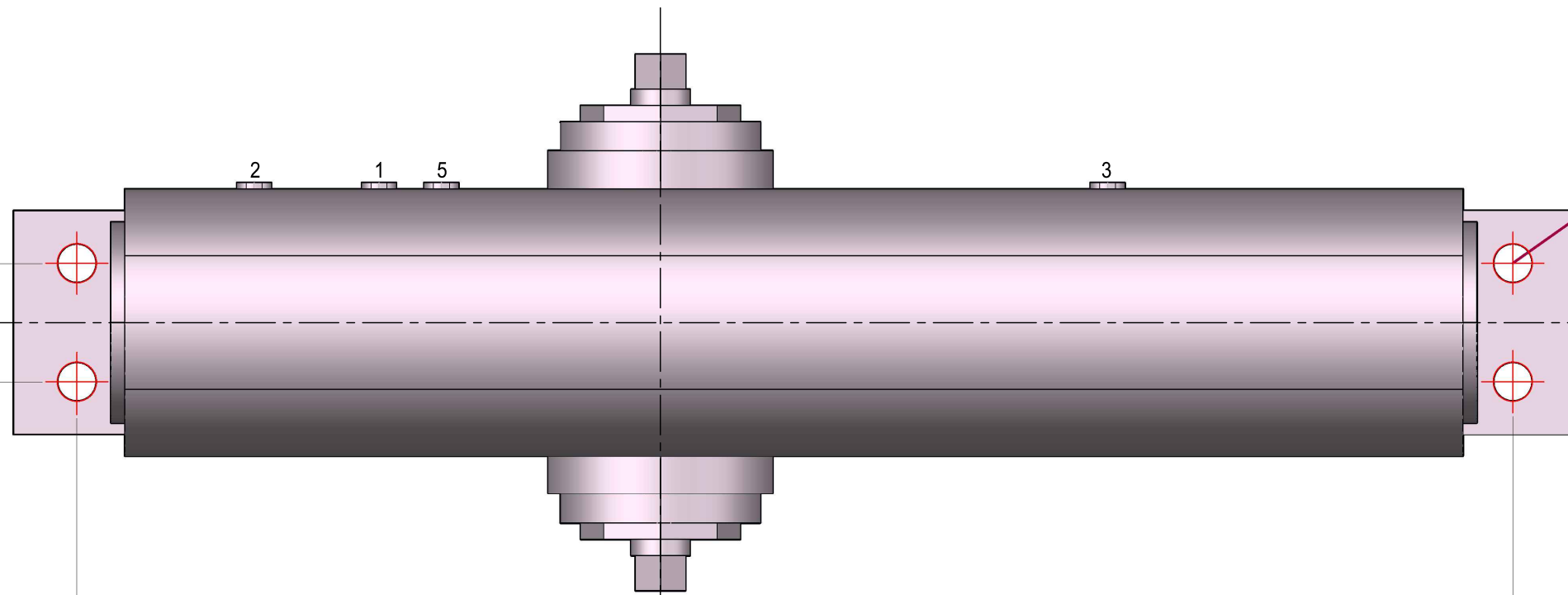

230mm (9 1/16")

100mm (3 15/16")

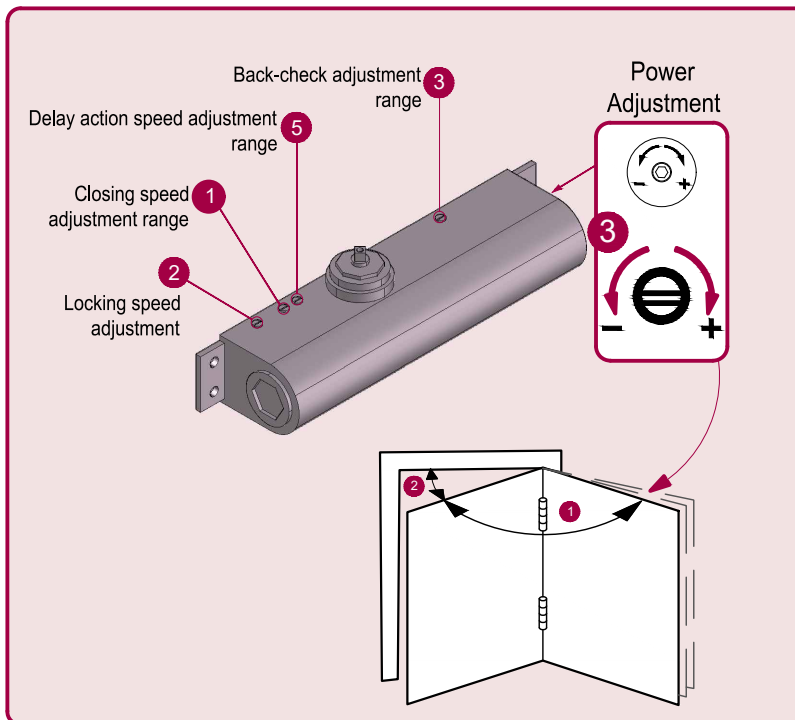
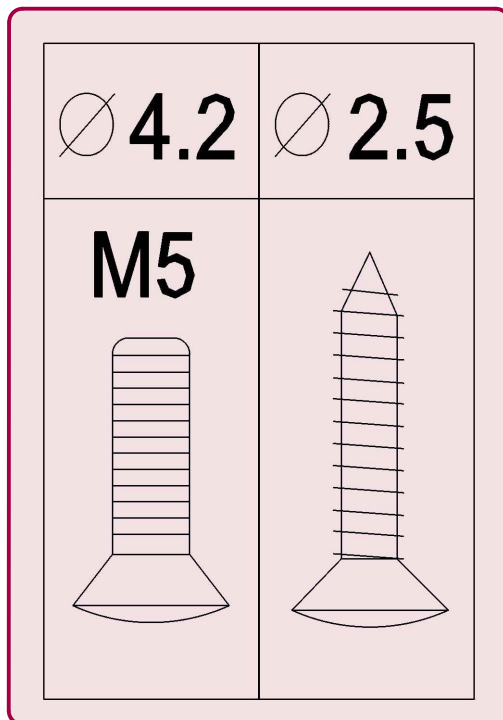
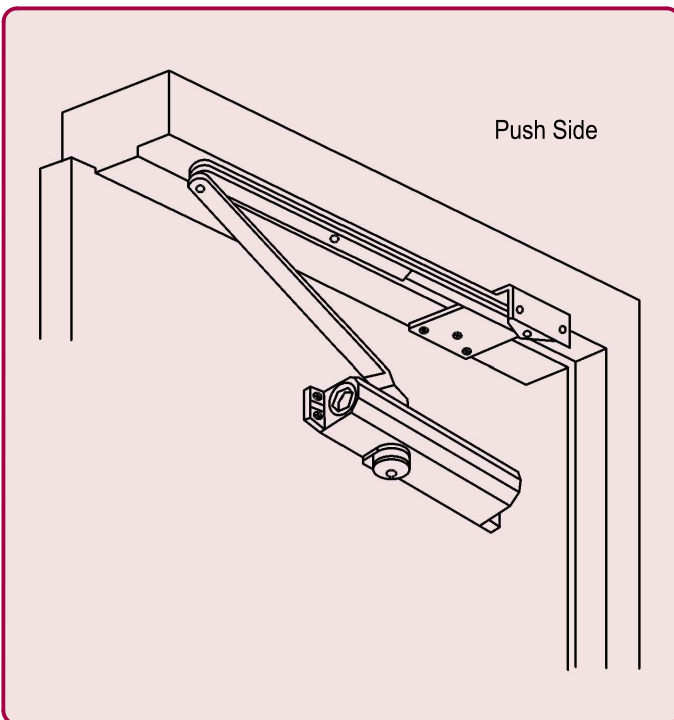
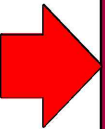

EN 2-4 Power Adjustment

4	+	-	+	+
No. of turns	EN Size	Max. door width	Max. opening angle	Max weight KG
-6	2*	850mm	180°	45
*0	3	950mm	180°	60
+6	4	1030mm	180°	80

* FACTORY PRE-SET
THE PINION BOLT MUST BE TIGHTENED TO 12NM.
NO PART OF THIS INSTRUCTION CAN BE COPIED OR STORED IN ANY WAY OR FORM MANUALLY OR ELECTRONICALLY WITHOUT THE FULL PERMISSION OF RUTLAND.
A MECHANICAL DOOR CLOSER IS NOT DESIGNED TO OVERCOME POOR FITTING, NOR TO OVERCOME EXCESSIVE AIR PRESSURES OR BINDING SMOKE AND WEATHER SEALS. EXCESSIVE AIR PRESSURES CAN BE CREATED BY THROUGH DRAFT, BY AIR CONDITIONING, BY SMALL ROOMS WITHOUT VENTILATION, OR WHERE NO AIR TRANSFERS GRILLS ARE FITTED. MECHANICAL DOOR CLOSERS ARE DESIGNED TO CLOSE THE STATED AND TESTED SPECIFICATION OF DOOR WEIGHT AND DOORSETS/DOOR ASSEMBLIES WHEN DOORS ARE FITTED WITH CORRECT GAPS AND NOT BINDING ON SEALS. IF YOU ENCOUNTER PROBLEMS WITH DOORS NOT CLOSING PLEASE WATCH OUR "6 WAYS TO TROUBLESHOOT A DOOR CLOSER" VIDEO WHERE DOORS ARE NOT CLOSING DUE TO AIR PRESSURES THEN PROFESSIONAL ADVICE FROM AN AUTHORISED INSTALLER IS RECOMMENDED TO FIT FIRE TESTED AND THIRD PARTY CERTIFICATED AIR TRANSFER GRILLS, AND/OR AUTOMATIC DOOR OPERATORS.



Parallel Arm Closer TS 4204DABCSR

UK
CA

1354

01246 261 491 www.rutlanduk.co.uk

Installation Steps:

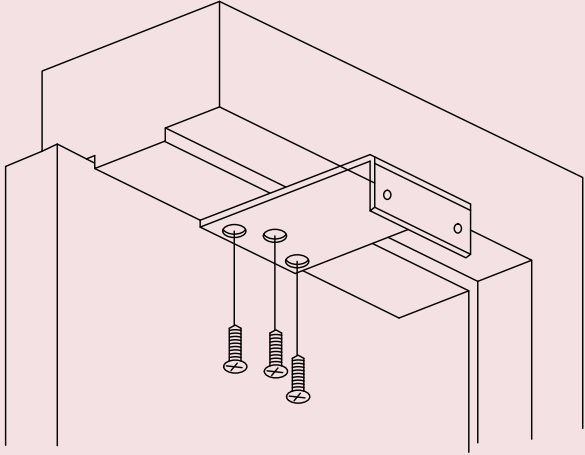
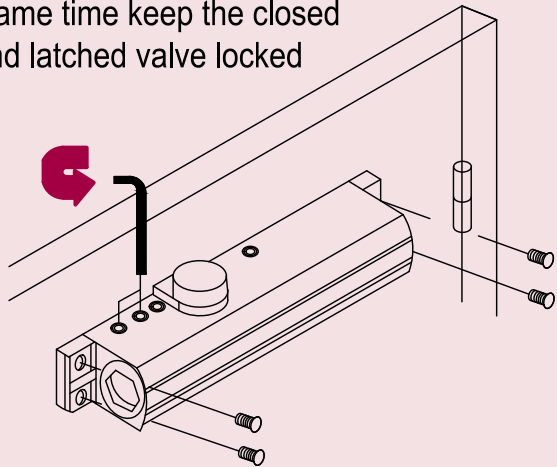
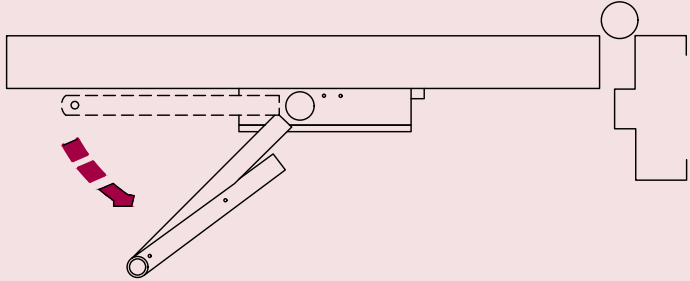
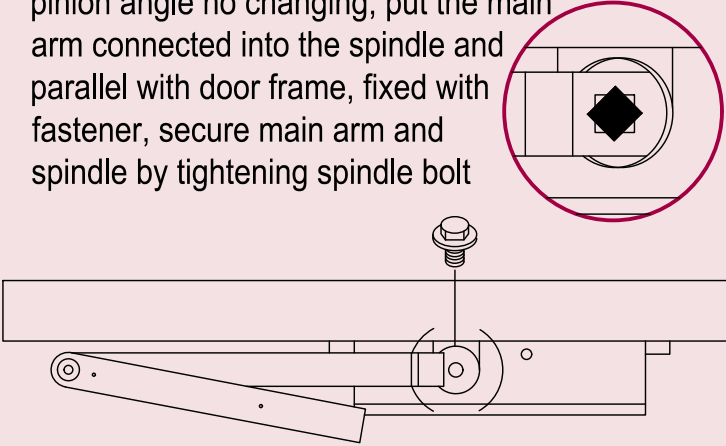
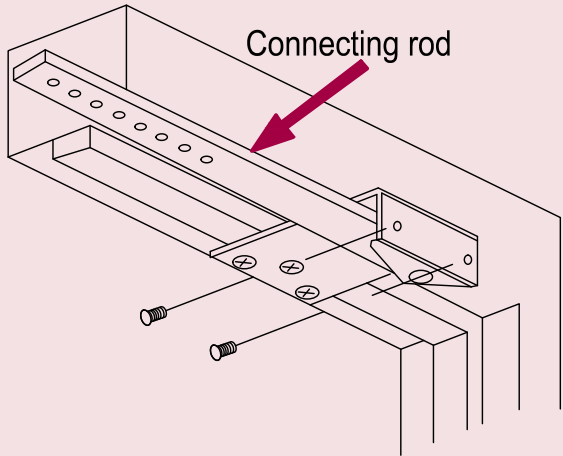
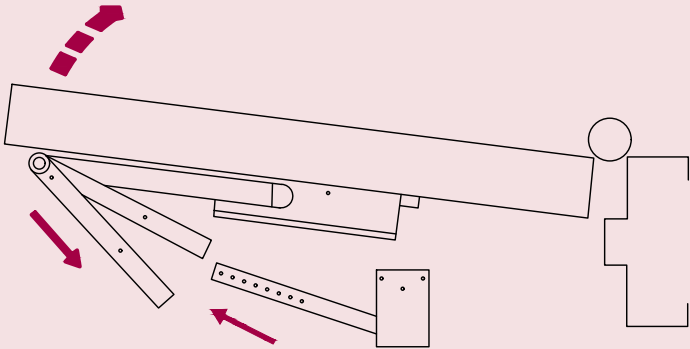
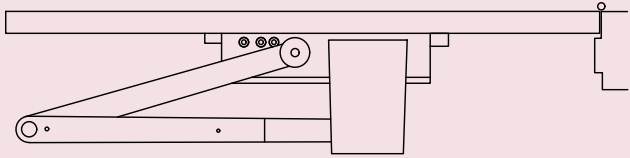
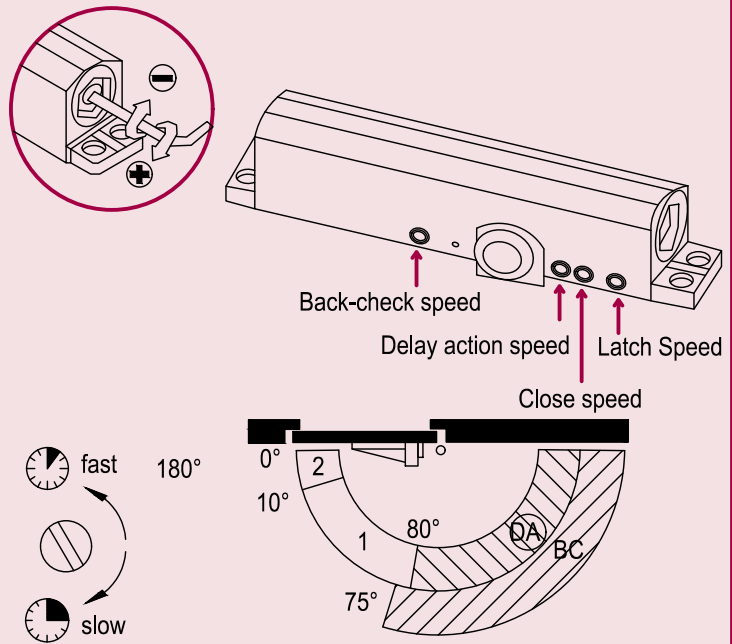
<p>1. Install parallel plate</p> <p>According to the installation dimensions by screws parallel plate fixed on a door frame</p> 	<p>2. Install door closer</p> <p>According to the size of installation by screws fixed to the door closers At the same time keep the closed valve and latched valve locked</p> 	<p>3. Preloading 45°</p> <p>The main arm is mounted on a shaft head frame in parallel and then along the clockwise 45 degrees</p> 	<p>4. Complete preloading</p> <p>Take out the main arm quickly, keep preloading pinion angle no changing, put the main arm connected into the spindle and parallel with door frame, fixed with fastener, secure main arm and spindle by tightening spindle bolt</p> 
<p>5. The installation of connecting rod</p> <p>The mounting bracket on the connecting rod is fixed on the parallel plate, with a screw fixation.</p> 	<p>6. Connect the connecting rod and the cover</p> <p>First open the door to a certain angle and according to the diagram, connect the connecting rod and the cover using screw fixation</p> 	<p>7. Diagrammatic sketch after installation</p> 	<p>8. Function adjustment</p> 



Parallel Arm Closer TS 4204DABCSR

UK
CA

1354

01246 261 491 www.rutlanduk.co.uk

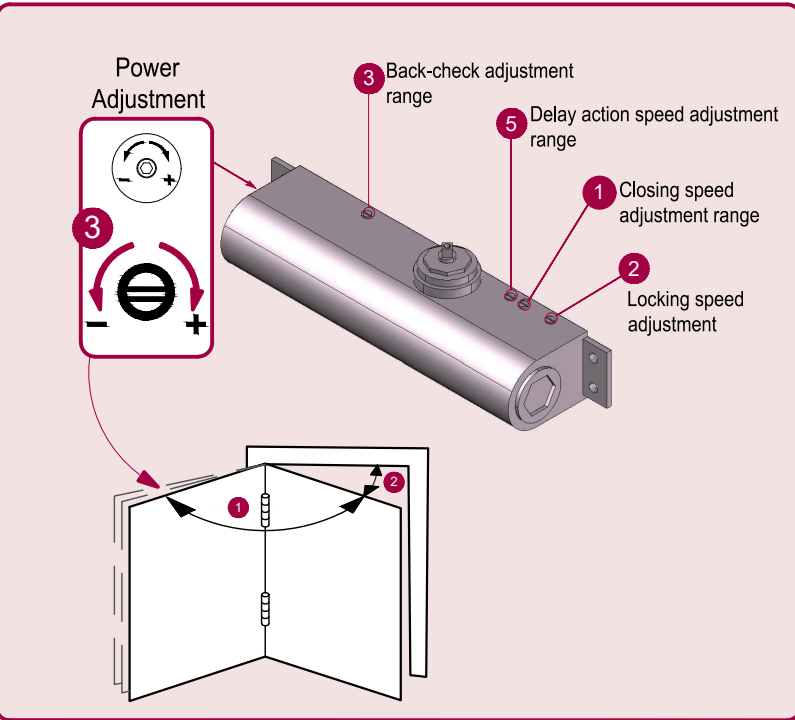
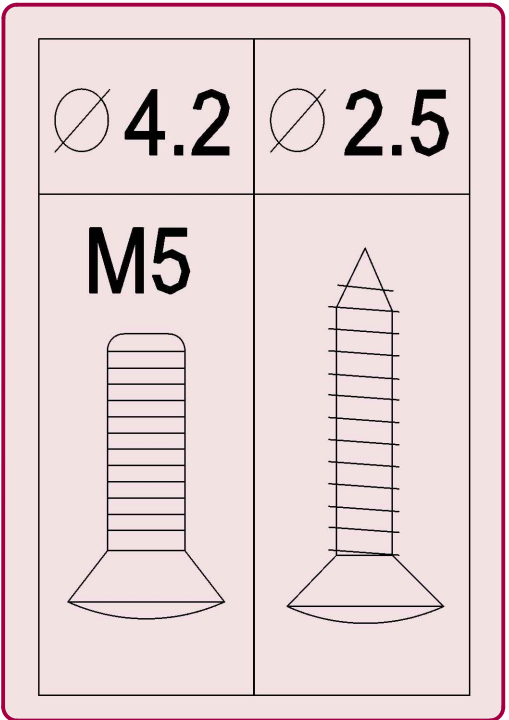
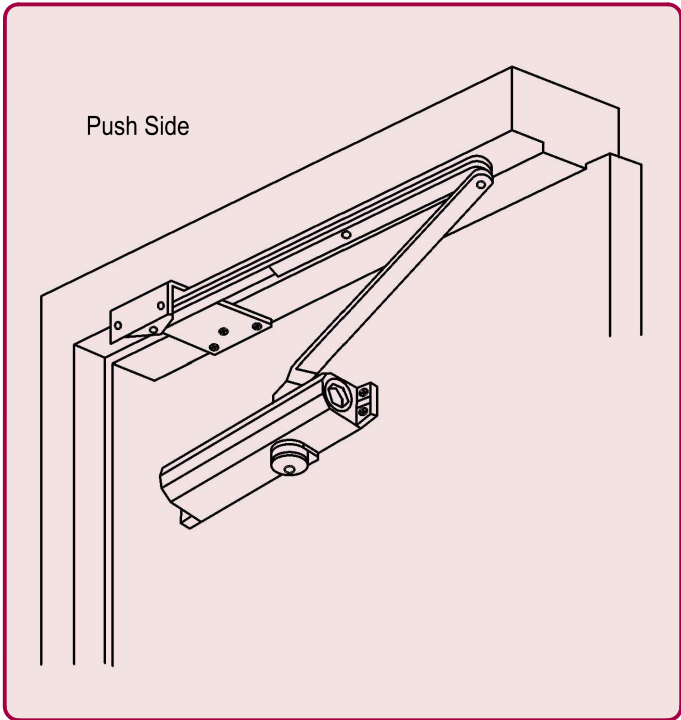
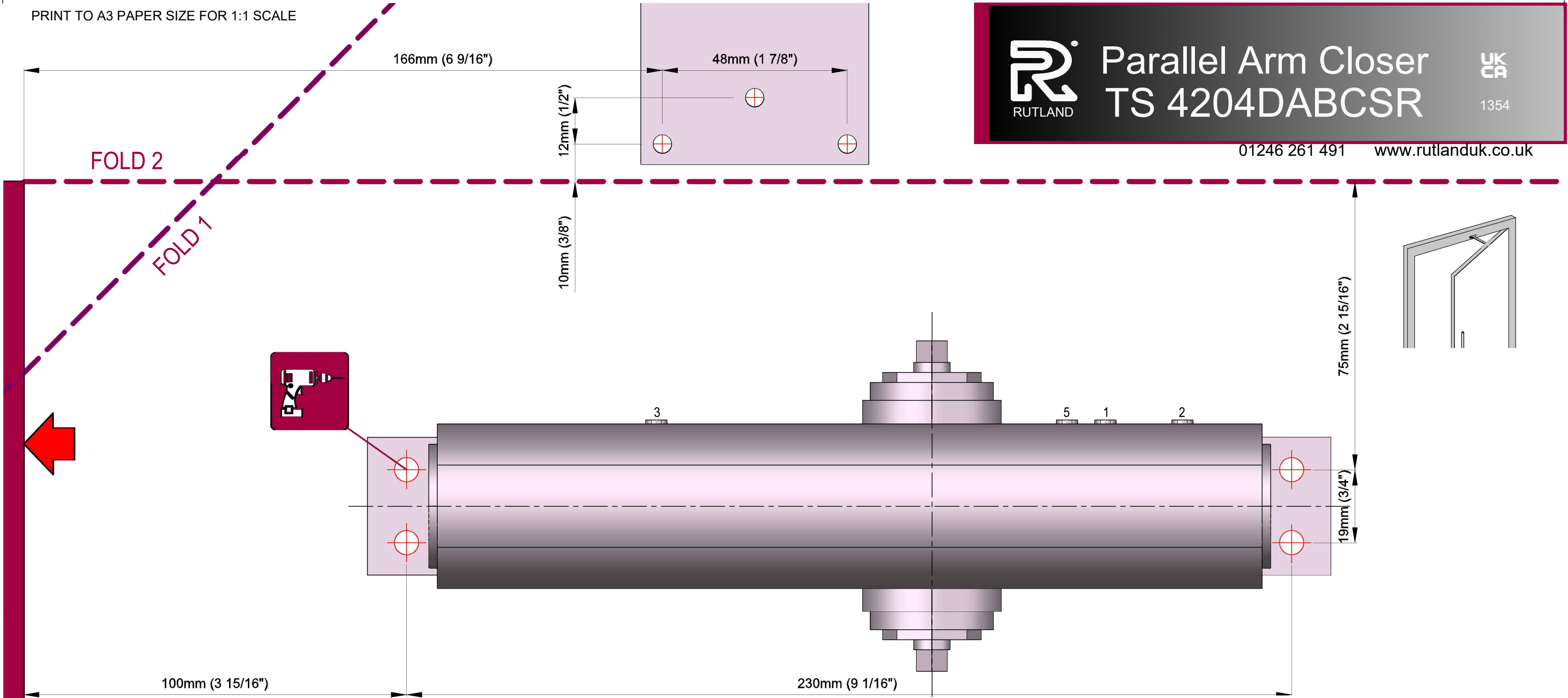

EN 2-4 Power Adjustment

4	+	+	+	+
No. of turns	EN Size	Max. door width	Max. opening angle	Max weight KG
-6	2*	850mm	180°	45
*0	3	950mm	180°	60
+6	4	1030mm	180°	80

* FACTORY PRE-SET
THE PINION BOLT MUST BE TIGHTENED TO 12NM.
NO PART OF THIS INSTRUCTION CAN BE COPIED OR STORED IN ANY WAY OR FORM MANUALLY OR ELECTRONICALLY WITHOUT THE FULL PERMISSION OF RUTLAND.
A MECHANICAL DOOR CLOSER IS NOT DESIGNED TO OVERCOME POOR FITTING, NOR TO OVERCOME EXCESSIVE AIR PRESSURES OR BINDING SMOKE AND WEATHER SEALS. EXCESSIVE AIR PRESSURES CAN BE CREATED BY THROUGH DRAFT, BY AIR CONDITIONING, BY SMALL ROOMS WITHOUT VENTILATION, OR WHERE NO AIR TRANSFERS GRILLS ARE FITTED. MECHANICAL DOOR CLOSERS ARE DESIGNED TO CLOSE THE STATED AND TESTED SPECIFICATION OF DOOR WEIGHT AND DOORSETS/DOOR ASSEMBLIES WHEN DOORS ARE FITTED WITH CORRECT GAPS AND NOT BINDING ON SEALS. IF YOU ENCOUNTER PROBLEMS WITH DOORS NOT CLOSING PLEASE WATCH OUR '6 WAYS TO TROUBLESHOOT A DOOR CLOSER' VIDEO WHERE DOORS ARE NOT CLOSING DUE TO AIR PRESSURES THEN PROFESSIONAL ADVICE FROM AN AUTHORISED INSTALLER IS RECOMMENDED TO FIT FIRE TESTED AND THIRD PARTY CERTIFICATED AIR TRANSFER GRILLS, AND/OR AUTOMATIC DOOR OPERATORS.



Parallel Arm Closer TS 4204DABCSR

UK
CA

1354

01246 261 491 www.rutlanduk.co.uk

Installation Steps:

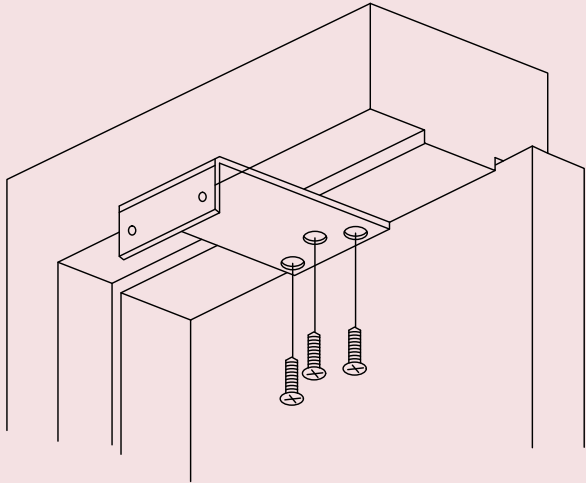
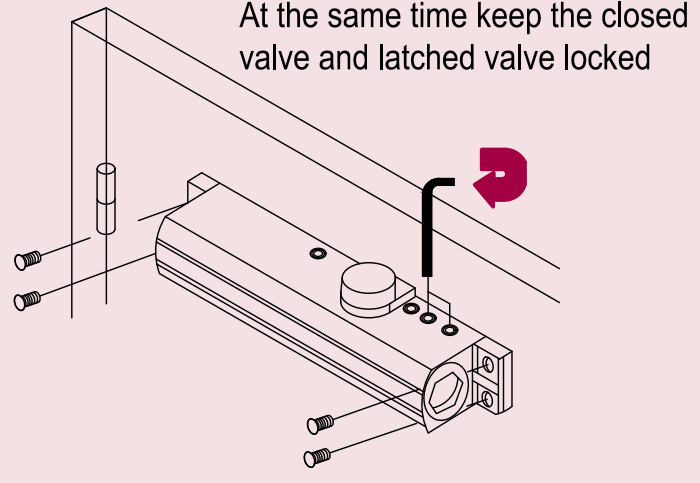
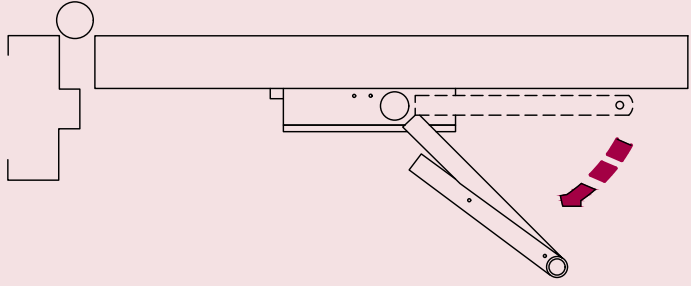
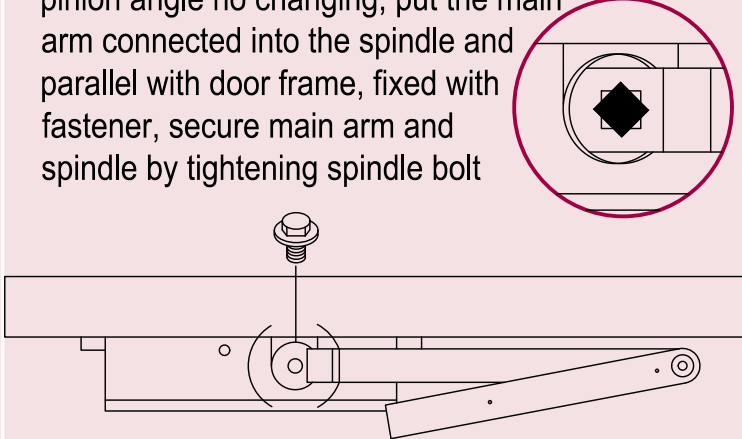
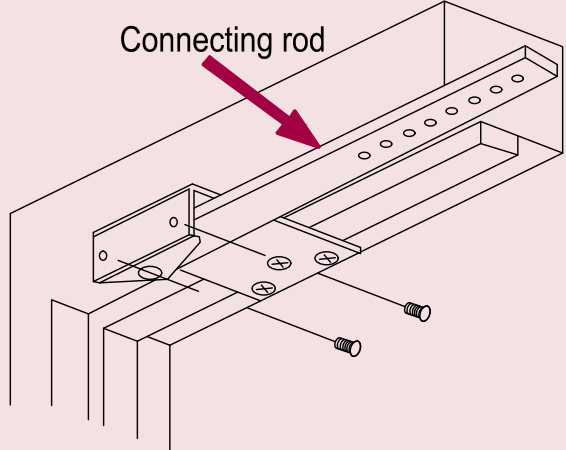
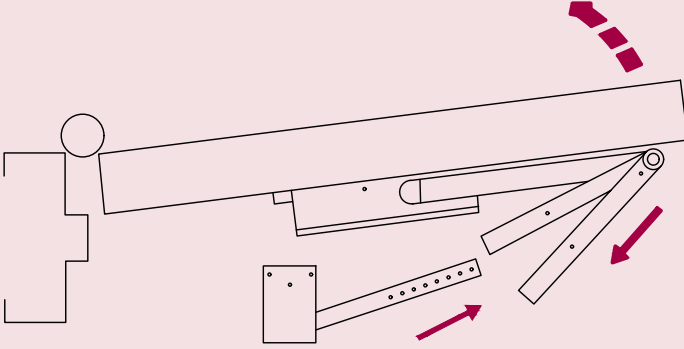
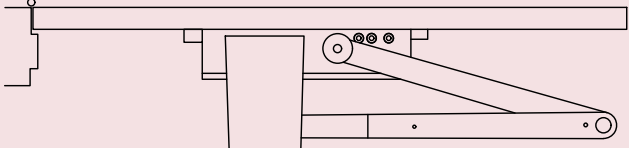
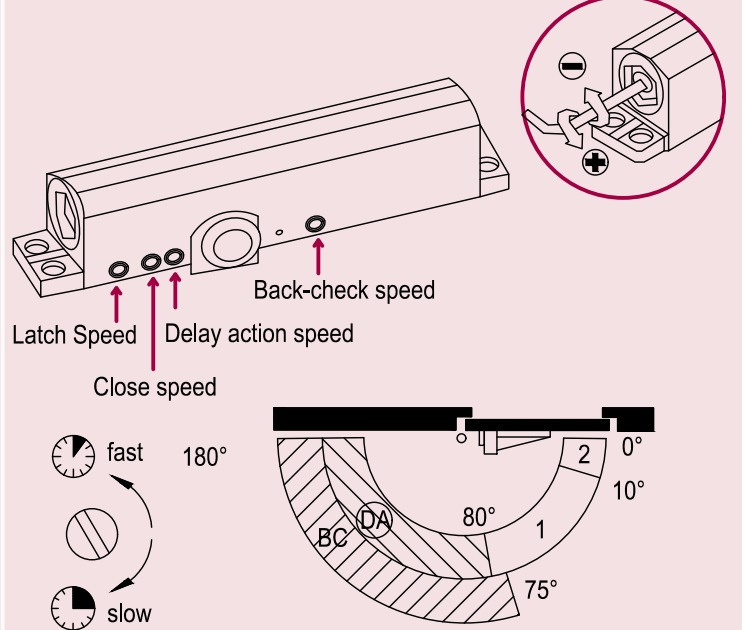
<p>1. Install parallel plate</p> <p>According to the installation dimensions by screws parallel plate fixed on a door frame</p> 	<p>2. Install door closer</p> <p>According to the size of installation by screws fixed to the door closers</p> <p>At the same time keep the closed valve and latched valve locked</p> 	<p>3. Preloading 45°</p> <p>The main arm is mounted on a shaft head frame in parallel and then along the clockwise 45 degrees</p> 	<p>4. Complete preloading</p> <p>Take out the main arm quickly, keep preloading pinion angle no changing, put the main arm connected into the spindle and parallel with door frame, fixed with fastener, secure main arm and spindle by tightening spindle bolt</p> 
<p>5. The installation of connecting rod</p> <p>The mounting bracket on the connecting rod is fixed on the parallel plate, with a screw fixation.</p> <p>Connecting rod</p> 	<p>6. Connect the connecting rod and the cover</p> <p>First open the door to a certain angle and according to the diagram, connect the connecting rod and the cover using screw fixation</p> 	<p>7. Diagrammatic sketch after installation</p> 	<p>8. Function adjustment</p>  <p>Latch Speed Delay action speed Back-check speed</p> <p>Close speed</p> <p>fast 180°</p> <p>slow</p> <p>0° 10° 75° 80° 180°</p> <p>BC DA</p>