



Enhancing **compliance**  
and **performance** at every door

# Automatic Door Closer for swing doors

## Fitting Instruction



- Installation of automatic door should be entrusted to the appointed distributor or professional installation personnel, otherwise it may be dangerous.
- According to the laws and regulations on electrical construction, installation must be carried out by professionals.
- This manual must be kept well for maintenance.

# Contents

Product introduction . . . . .	1
Technical Parameters . . . . .	2
Standard/optional accessories. . . . .	3
Product Introduction . . . . .	4
Pull/Push arm selection . . . . .	5
Installation direction. . . . .	6
Installation (Pull arm) . . . . .	7-8
Installation (Push arm) . . . . .	9-10
Product Adjustment . . . . .	11-12
Parameter setting . . . . .	13-14
Terminal information . . . . .	15
Wiring Diagram	
Synchronous for double open/lock - AO.SDLink . . . . .	16
Infrared safety top scan sensor - AO.IRSS.700 . . . . .	17-22
Press button - AO.PB . . . . .	23
Remote - AO.REC. . . . .	23
Function Switch - AO.SWITCH . . . . .	23
Access Keypad - AO.KEYPAD. . . . .	23
Data Setting . . . . .	24
Status and Error Indicate . . . . .	25

# Product Introduction

## Product Information

- Application : Timber door, steel door and composite door
- Adjustable performance: 35 parameters are adjustable.
- Door Width: 700mm - 1400mm
- Door weightL Max 350kg (Fig. 1)
- Door opening angle: 45°- 105°
- Fitting direction: Pull and Push
- Voltage: AC 220V (±10%) / AC 110V (±10%)
- Open mode: Sensors, Remotes, Keypad, etc.
- Working life: Over 2 million times.

## Product Features



Automatic/Manual/Full open  
3 modes switch



Spline shaft design  
Strong connection



33mm 55mm 85mm

3 Types extension  
Meet different installation space.



Built-in spring design  
Work as door closer,  
when no power.

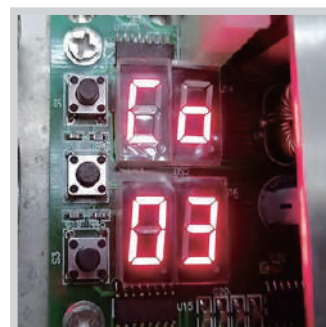

LED display , Easy operation



Low energy mode,providing  
disabled access solution.

# Technical Parameters

Size	610 x 90 x 128mm (W x H x D)
Voltage	110V/220V
Power	Standby 13W, rated 87W
Maximum Torque	50Nm
Opening Angle	45° - 105° (Adjustable)
Delay Time	0 - 30s (Adjustable)
Opening Speed	3 - 9s (Adjustable)
Closing Speed	3 - 9s (Adjustable)
Noise	18dB (Tested in 1m distance)
Max Weight	350kg

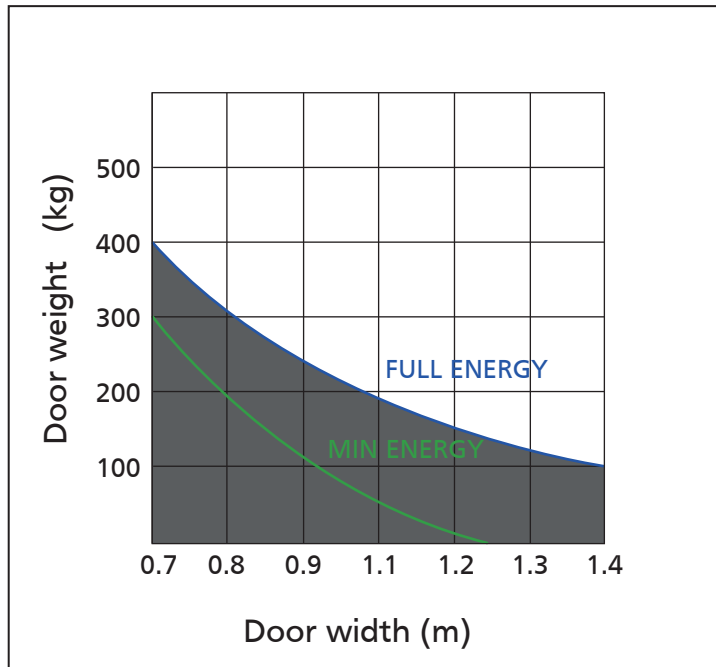

(Fig 1)

# Standard/Optional Accessories

Product Code	Re-order code	Description
AO.SD3	12798	Rutland Swing Door Automatic Operator with Pull Bar Slide Arm
AO.SD3.EXT55	12804	Automatic Swing Door Closer with Pull Bar Slide Arm Extension - 55mm
AO.SD3.EXT85	12805	Automatic Swing Door Closer with Pull Bar Slide Arm Extension - 85mm
AO.IRSS.700	12799	Infrared safety top scan sensor - 700mm
AO.RFG.1925	1XXXX	Roller Finger Guard FP60 1925 Metal SAA and Black Fabric
AO.KEYPAD	12800	Rutland Access Keypad
AO.CARD	12801	ID Card for access control
AO.FOB	12802	ID key chain button
AO.REC	12804	Automatic door function remotes
AO.SDLink	12804	Link module for double door

## Core Product



AO.SD3

## Optional Accessories



AO.SD3.PUSH ARM



AO.IRSS.700



AO.SD3.EXT55



AO.SD3.EXT85



Electromagnetic Lock



AO.FOB



AO.CARD



AO.KEYPAD



RAL900

# Product Introduction

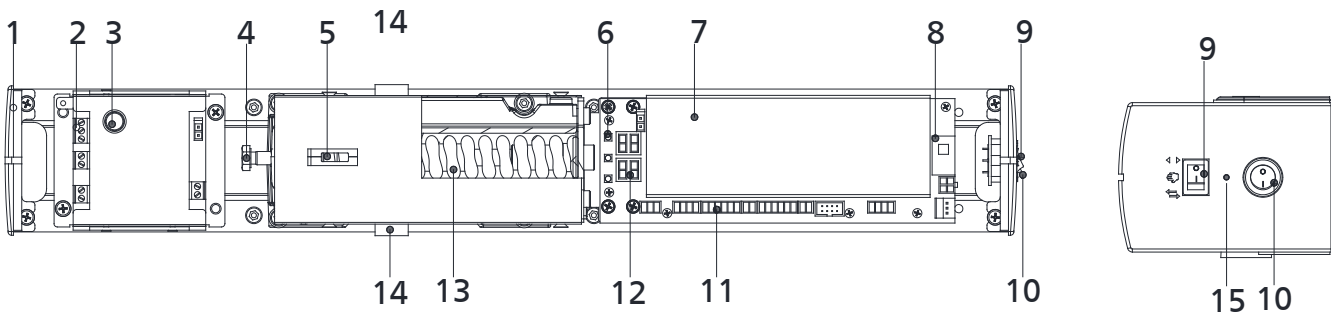

- |                                 |                                    |                       |
|---------------------------------|------------------------------------|-----------------------|
| 1.Side cover                    | 6.Parameter adjustment button      | 11.Wiring terminal    |
| 2.Power input                   | 7.Controller                       | 12.LED display        |
| 3.Fuse                          | 8.Push / pull arm selection switch | 13.Spring             |
| 4.Spring force adjustment screw | 9. Mode switch                     | 14.Motor output shaft |
| 5. Windows                      | 10.Power switch                    | 15.Power indicator    |

### 9. Mode switch:

◁ ▷ Hold open mode: The door will remain open at this mode.

☞ Manual mode: The door open manually, and close automatically.  
All sensors can't work.

↔ Automatic mode: The door work automatically, all sensors can work.

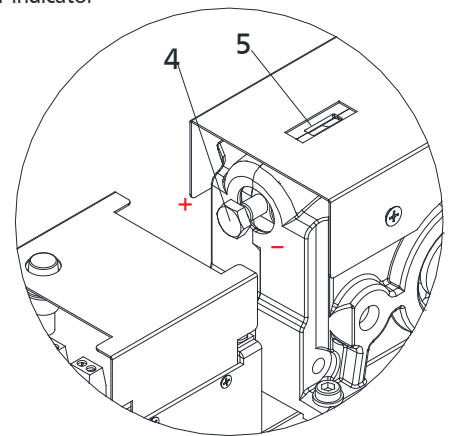

The spring force is different according to the width of the door leaf, so the spring force needs to be adjusted. The specific adjustment can be based on different door width. When adjusting, the wind pressure and overpressure / low pressure should also be fully considered (The door must be automatically closed in place when the power is turned off). The factory settings of the operator is the minimum spring force, which is suitable for the width of the 750mm-900mm

Adjust the screw clockwise to increase the spring force;counter clockwise to decrease force.  
Improper spring force may cause failure operation.

# Pull/Push Arm Selection

## Pull arm

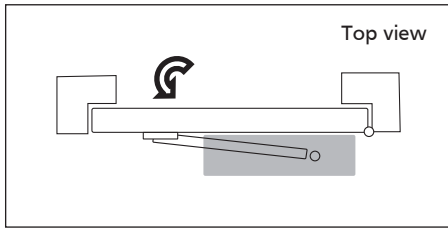
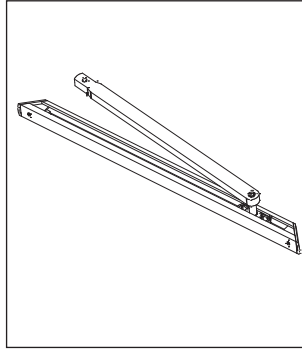
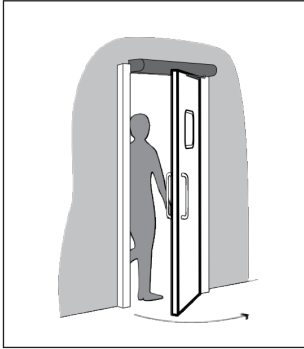

Single open

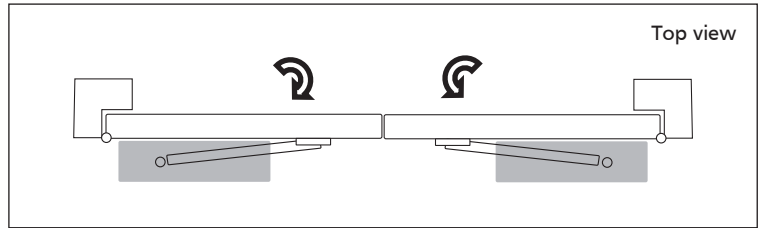

Double open

## Push arm

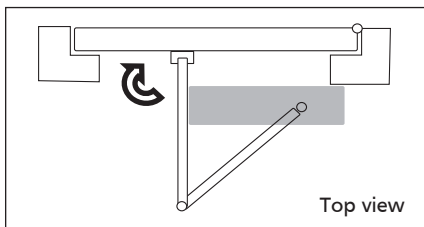
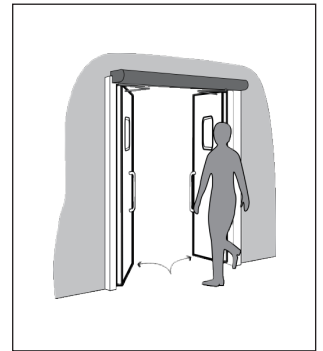
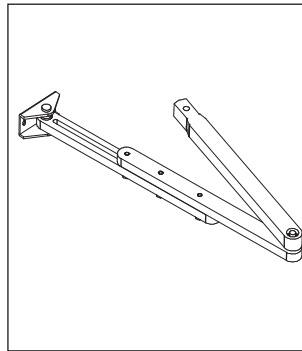

Single open

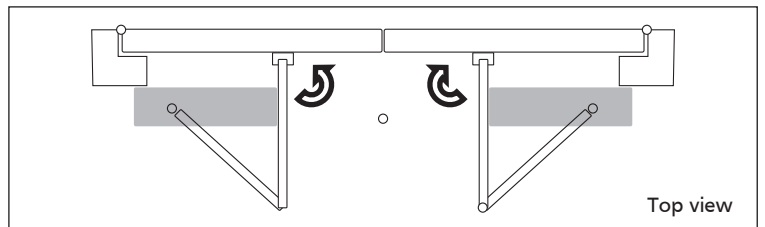

Double open

# Installation Direction

## Direction of operator installation

Factory default is left open. If it is Right open, you need to remove the motor, transformer and side cover by yourselves and rotate them by 180° and reassemble them.

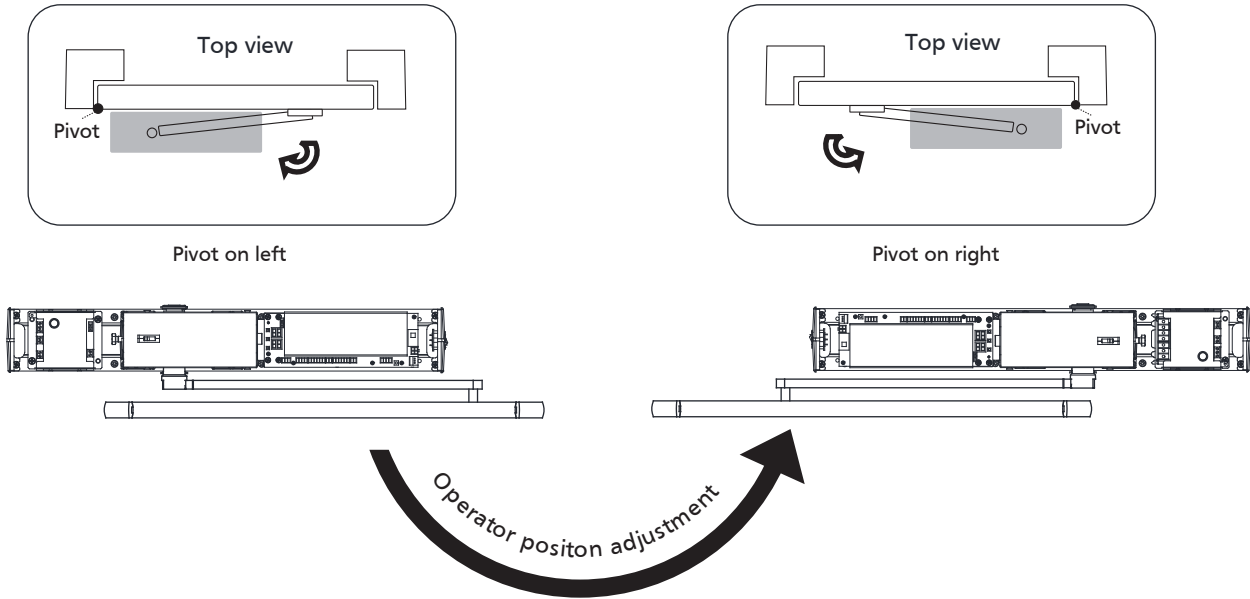

## Install on the left

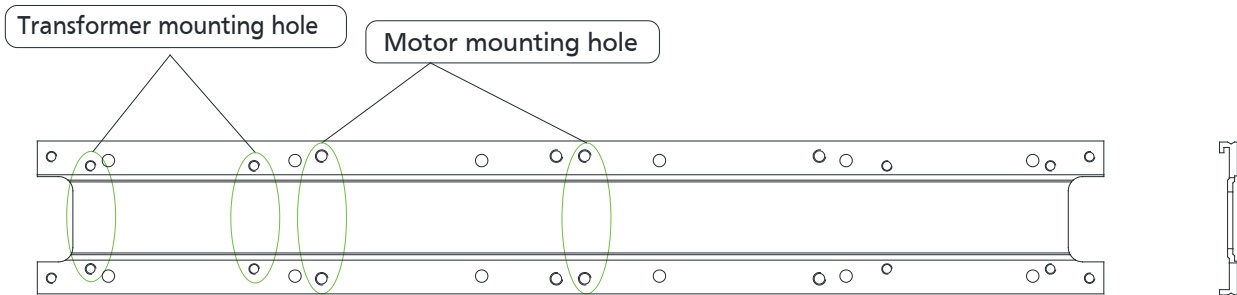

## Install on the right

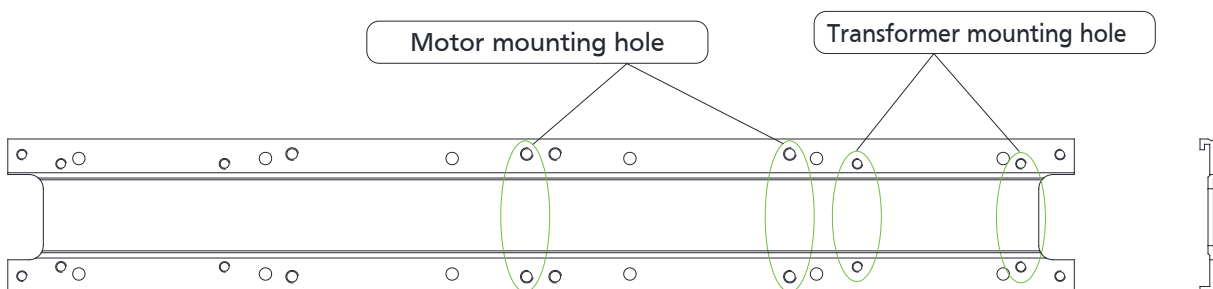

# Installation (Pull Arm)

Install on the left

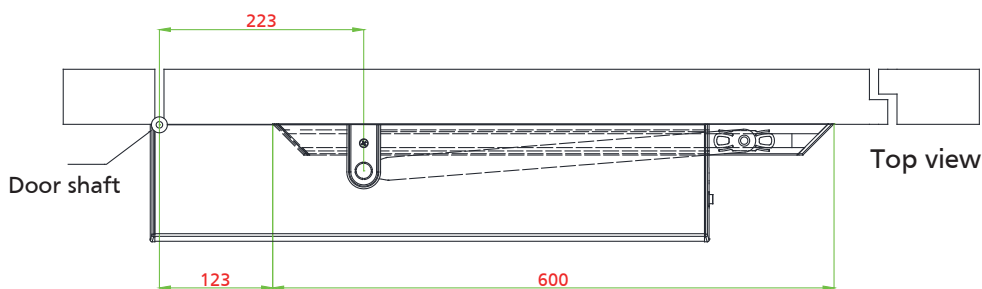
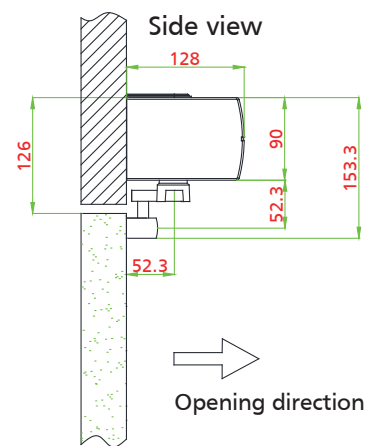
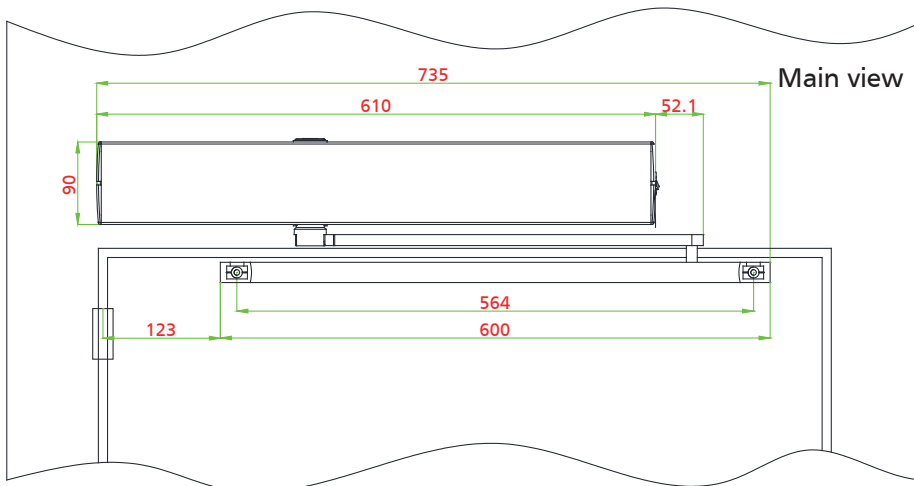
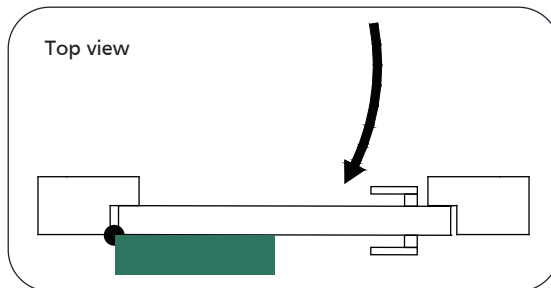
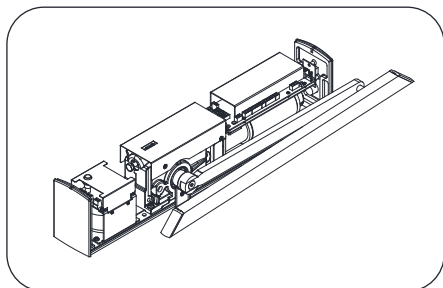

Bottom plate installation

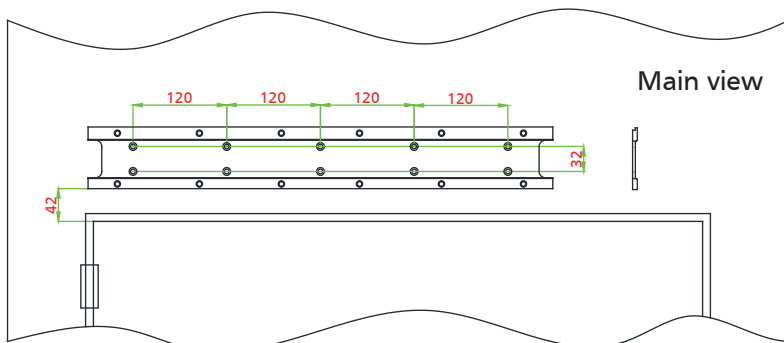

Install on the right

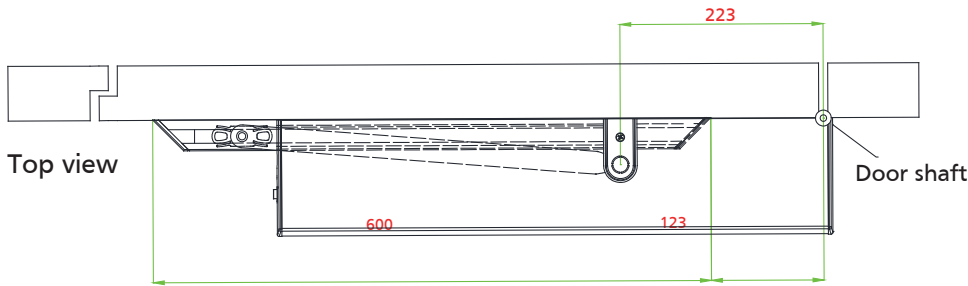
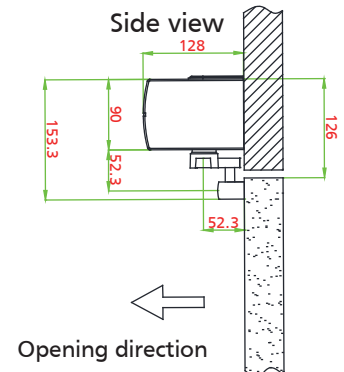
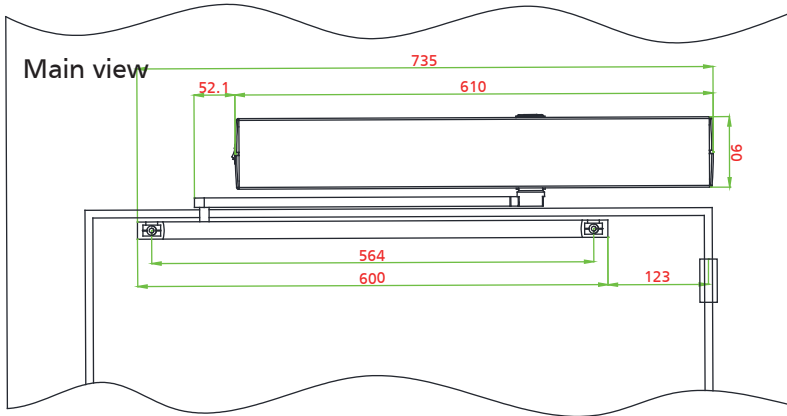
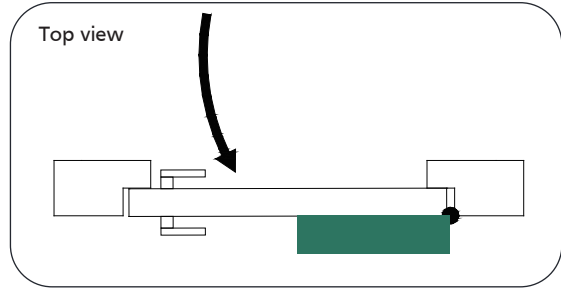
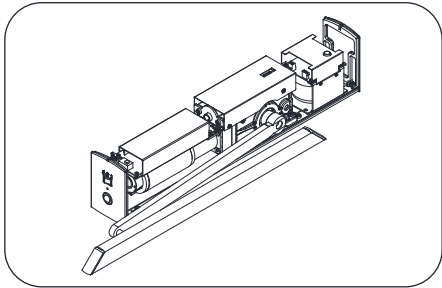

Bottom plate installation

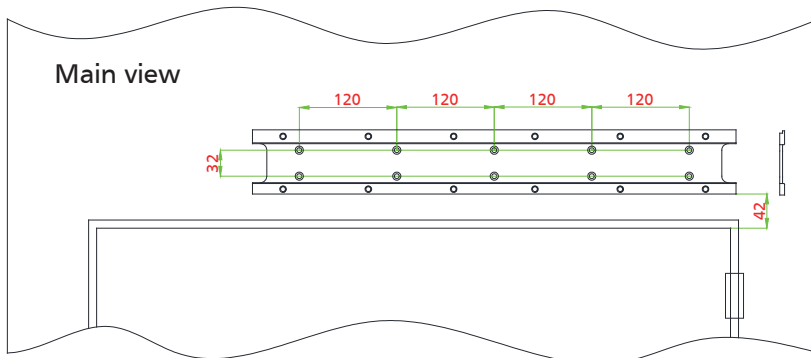

# Installation (Push Arm)

## ● Install on the left

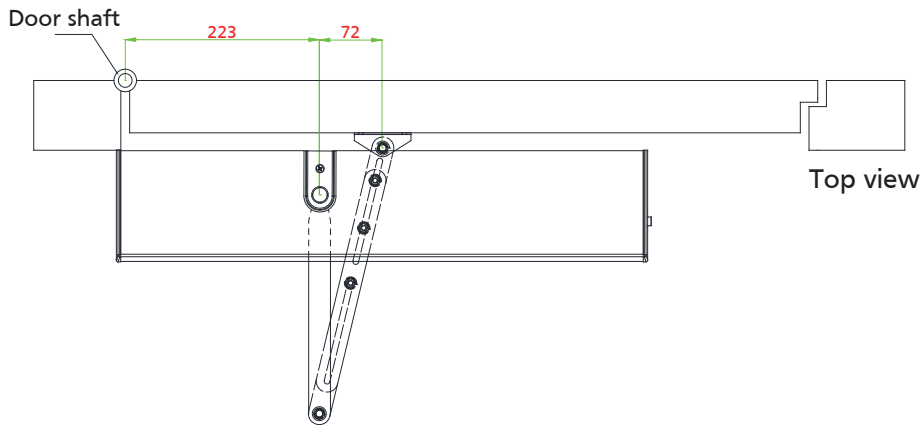
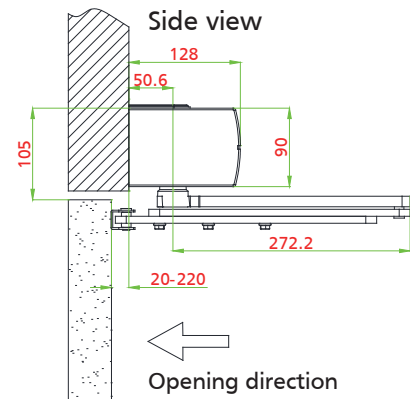
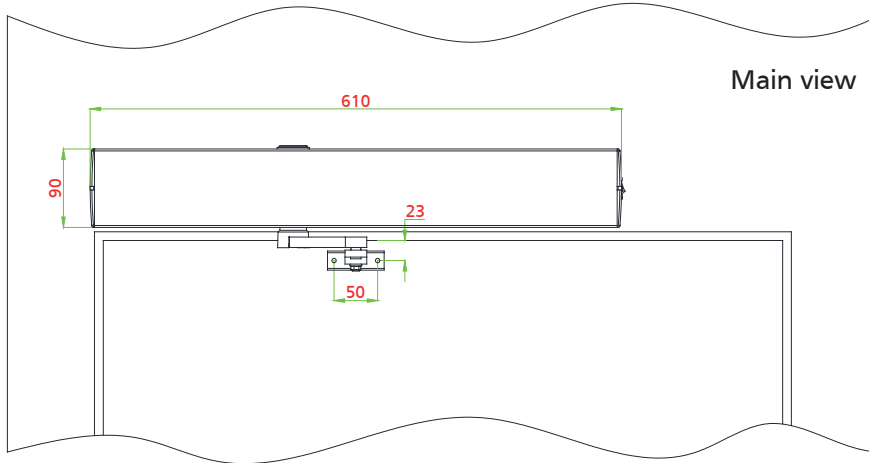
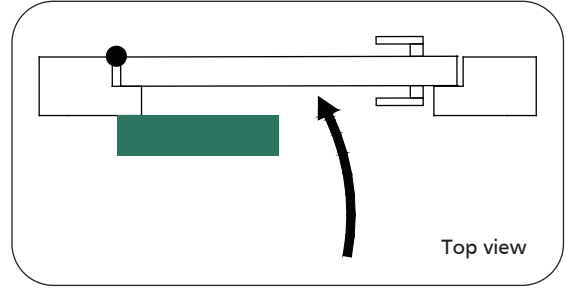
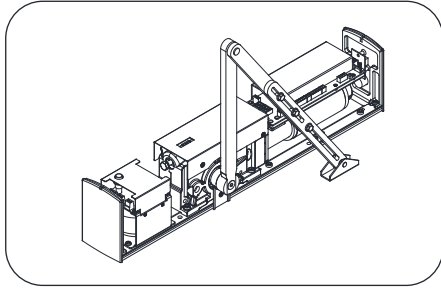

## ● Bottom plate installation

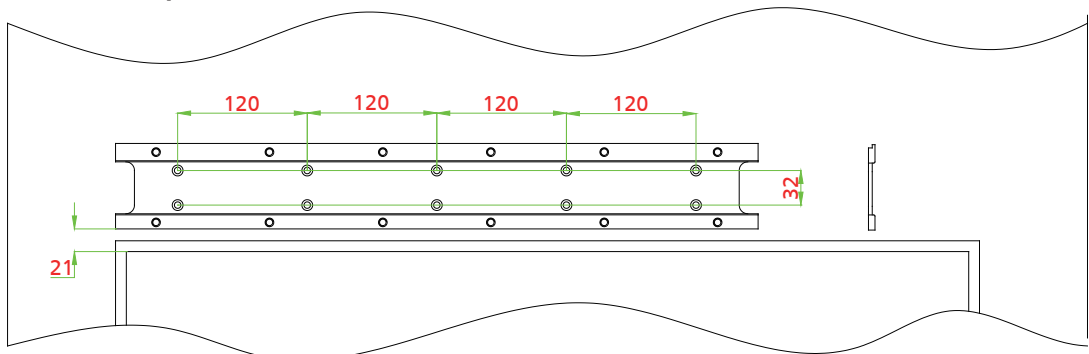

● Install on the right

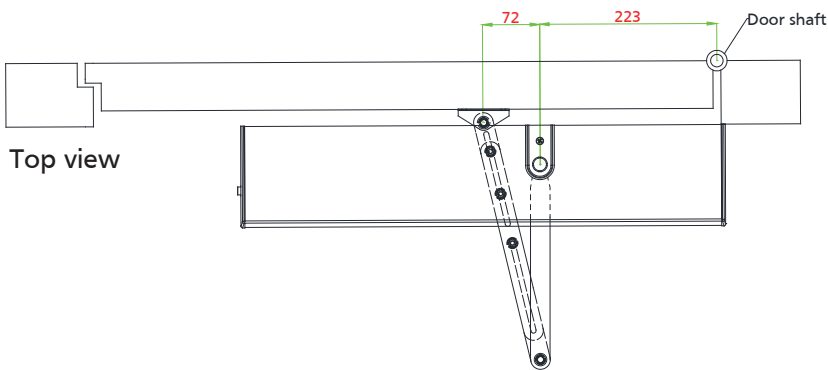
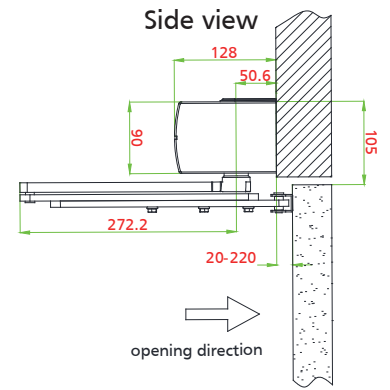
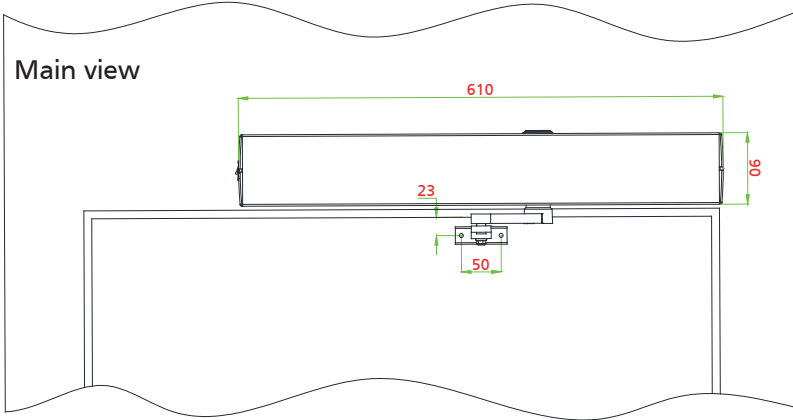
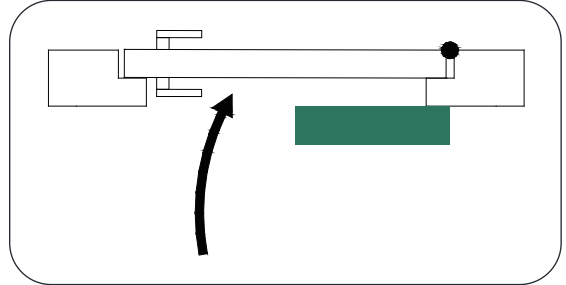
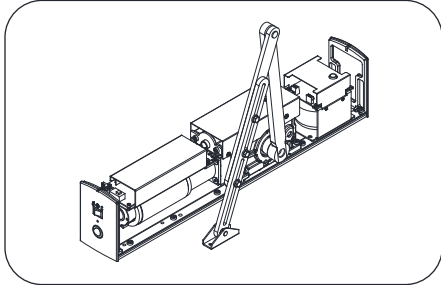

● Bottom plate installation

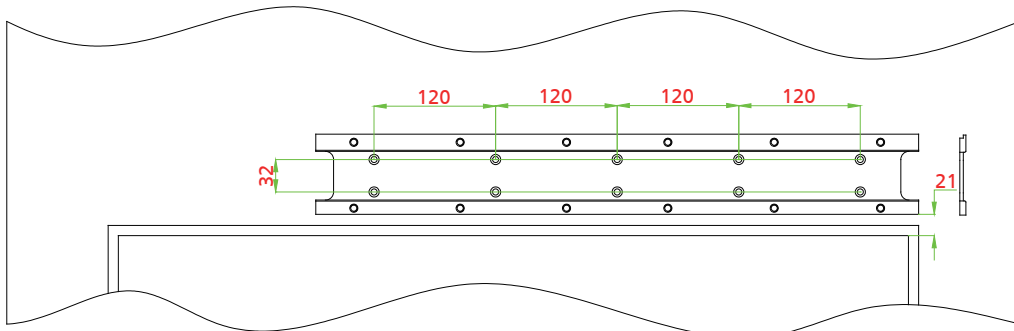

# Product Adjustment

If the door panel still cannot be closed completely after increasing the torsion of the spring, it needs to be adjusted according to the following methods

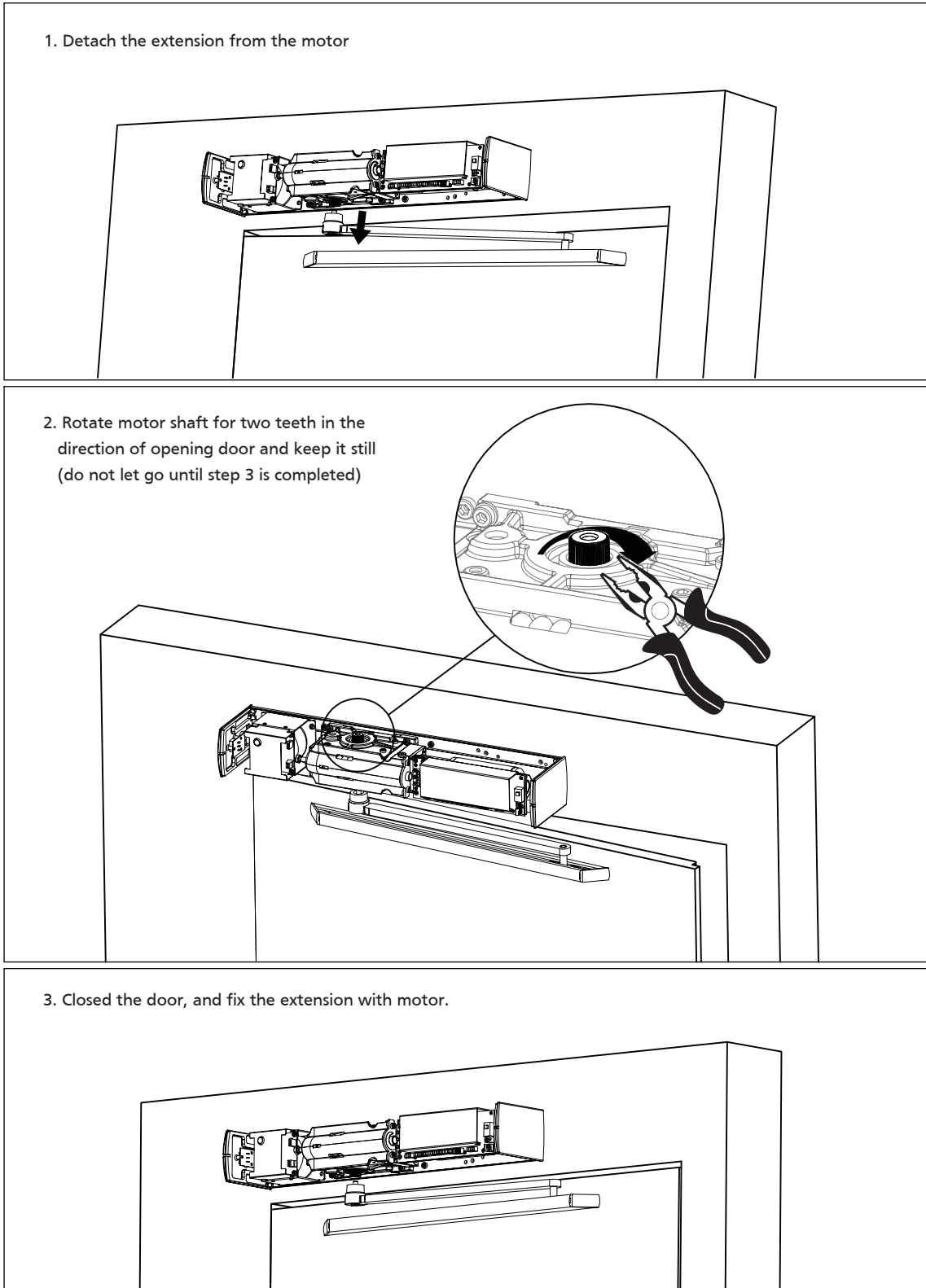

Note: After installation and debugging of the two doors, Set Pn27 of the master door's controller to 03, And Set Pn27 of Slave door's controller to 04

## Adjustment step before power on

1. Remove obstacles in the running track of the door.
2. Ensure the stopper has been installed at the right position.
3. Open the door to 90 degrees, and ensure the door moving smoothly.
4. Ensure door can close slowly from full open position.
5. Ensure door power supply meet requests

Note: If the door panel cannot be closed completely, adjust the spring force adjustment screw clockwise to increase the torque; If the door panel still cannot be closed after the spring torque is increased, please refer to the adjustment method on Page 13.

## Self-learning steps

1. Turn on power switch, the indicator on power supply will be lighting.
2. The controller start to self-test.
3. Display Fn00 to F99 parameter initialization.
4. Master and slave connection self-testing (Double open mode).
5. Motor direction and encoder signal self-testing.
6. Door slowing moving to closed position.
7. Showing"CXX": Self-learning finished.

## Attention

1. Obstacles not allowed during the door running track.
2. Turn off the power immediately if the door is out of control.
3. Push and pull bar's setting must be correct

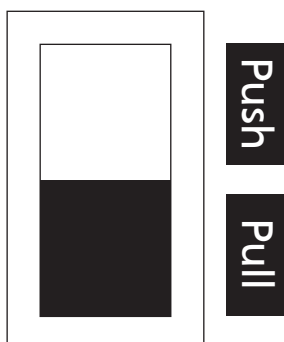

# Parameter Setting

## Parameter setting steps

**A. Basic Parameter:** There is a setting and display panel on the main control board for adjusting the operating parameters of the door and displaying the error code  
 Note: Total 35 items of parameter can be adjusted on controller

**B. Mode selection:**

1. Press mode select switch to Manual mode

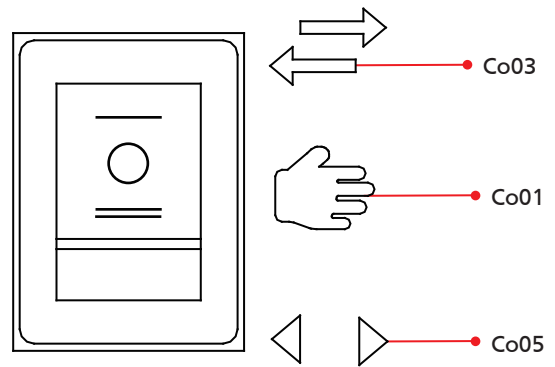
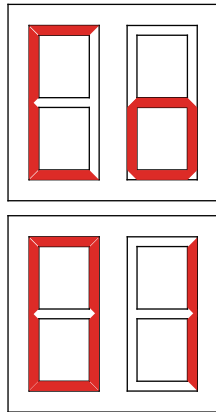

2. Press mode select switch to Automatic mode

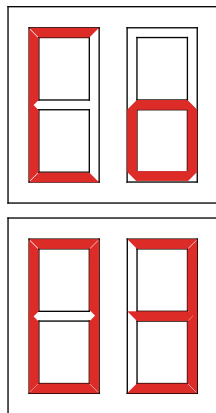

3. Press mode select switch to Always Open mode

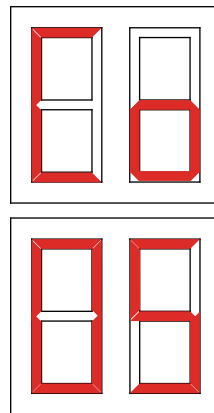

**C. Parameter adjustment**

1. Parameter adjustment must under Manual mode

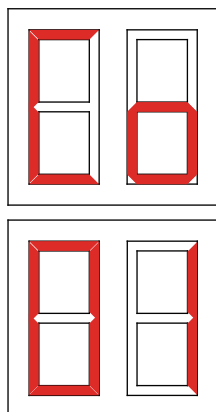

2. Keep pressing setting button 3 seconds
3. Enter the program selection after controller display Pn00
4. Press "+" or "-" button to select the program code (value from 00-35)

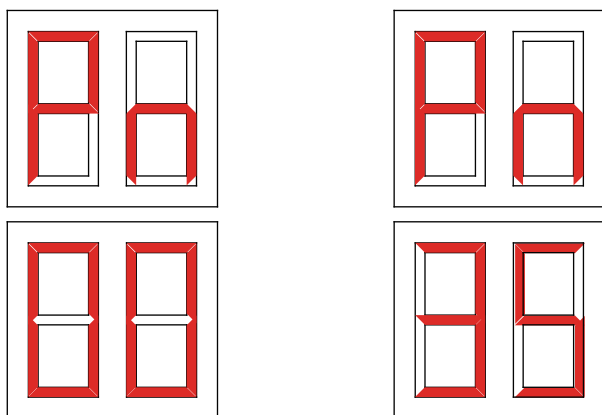

5. Press setting button to enter the value adjustment.
6. Press "+" or "-" button to adjust the value of program code.

(Min and Max value is limited by software)

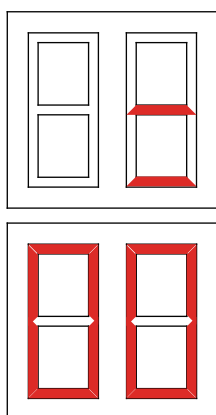

7. After pressing the set bottom, the value is saved, and back to the code selecting.
8. Continue step 4 to step7, adjust the code value as customer request.
9. After the function parameter setting is completed, it is necessary to return to the interface of "FN00" and then press the "SET" button to exit the parameter setting (Or stopping for 20 seconds at the interface of any parameter adjustment will automatically exit the parameter setting)

# Terminal Information

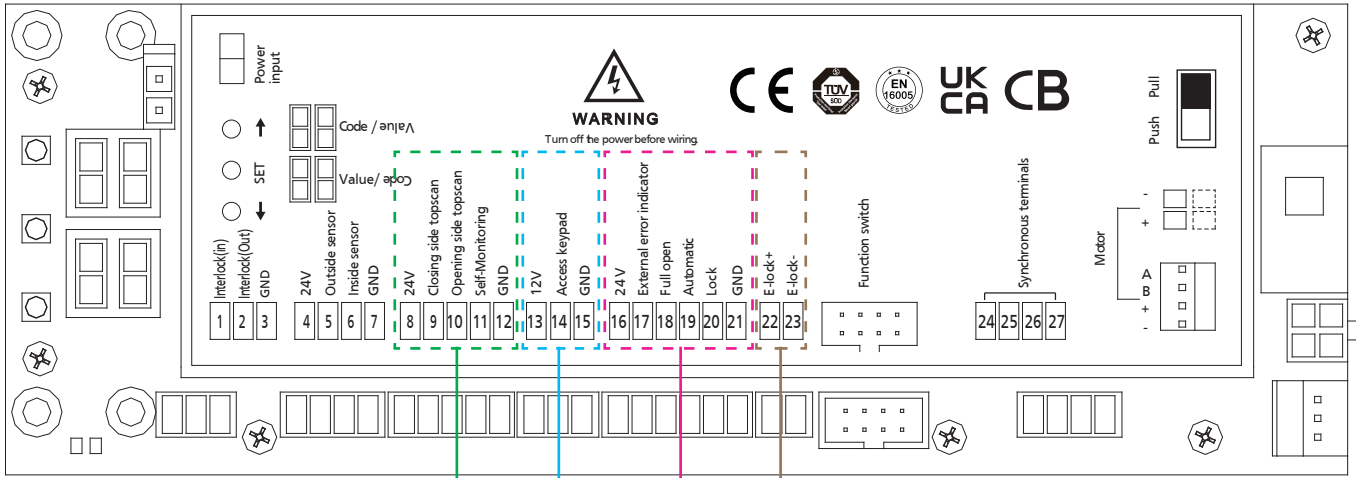

Top scan sensor    Keypad    Wireless Switch    Electric Release

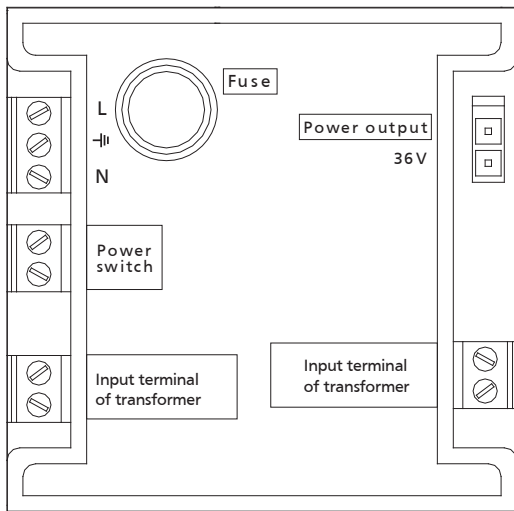

1	Interlock(in)
2	Interlock(Out)
3	GND
4	24V
5	Outside sensor
6	Inside sensor
7	GND
8	24V
9	Closing side topscan
10	Opening side topscan
11	Self-test signal
12	GND
13	12V
14	Card reader
15	GND

16	24V
17	Error feedback output
18	Full open
19	Automatic
20	Lock
21	GND
22	E-lock+
23	E-lock-
24	Synchronous signal
25	
26	
27	

## Connection of Inter-lock

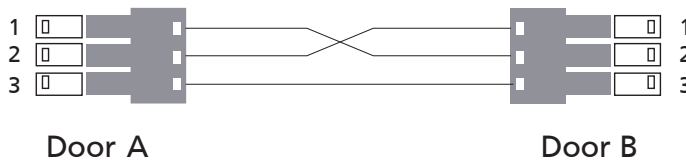

# Wiring Diagram

## Synchronous for double open

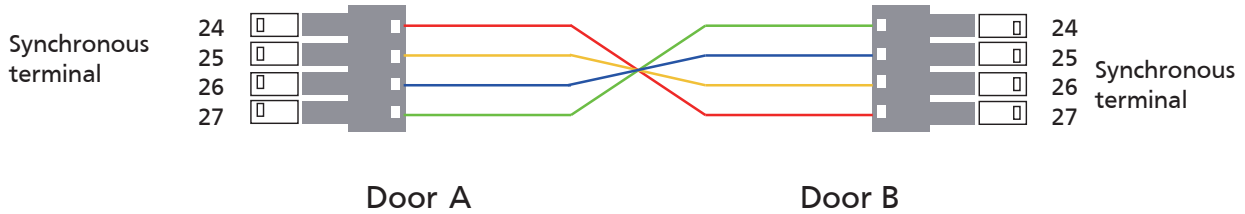

Note: Set Pn27 of the master door's controller to 03, And Set Pn27 of Slave door's controller to 04

## Electronic bolt lock and Magnetic lock

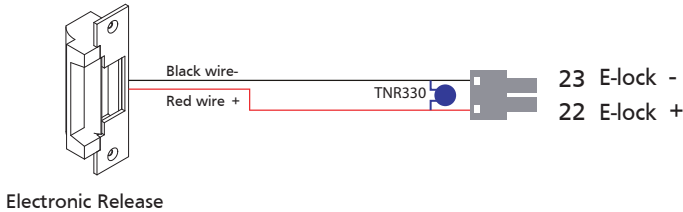
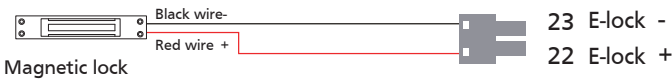
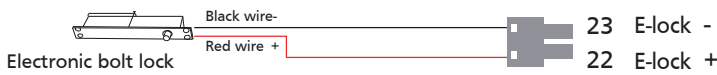

Note: For double opening, The Electronic bolt lock and Magnetic lock of the master door can only be connected to the controller of the master door; The Electronic bolt lock and Magnetic lock of the slave door can only be connected to the controller of the slave door.

 Please reference to Electronic Magnetic Lock and Electronic Release fitting instruction for detail

## Bridge connect terminal

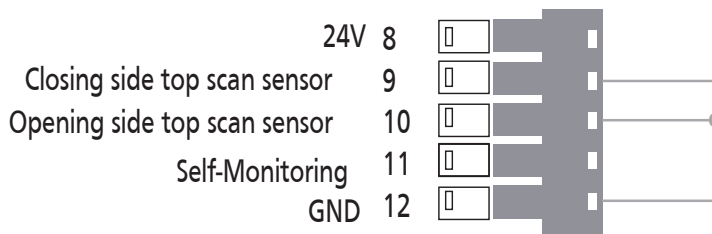

Note: If the top scan sensor is not connected, short-circuit the opening and closing Top Scan Sensor terminal to the GND terminal.

Pn32 Parameter Values  
(Controller monitoring output signal selection)

00-03	Low Level monitoring output
04-07	High Level monitoring output
00, 04	Unmonitored
01, 05	Monitor internal Top Scan sensor only (closing side)
02, 06	Monitor external top scan sensor only (opening side)
03, 07	Monitor internal and external top scan sensors (both side)

# Infrared Safety Top Scan Sensor

## 1. Turn off monitoring function

### 1.1 Opening side (AO.IRSS.700 Master)

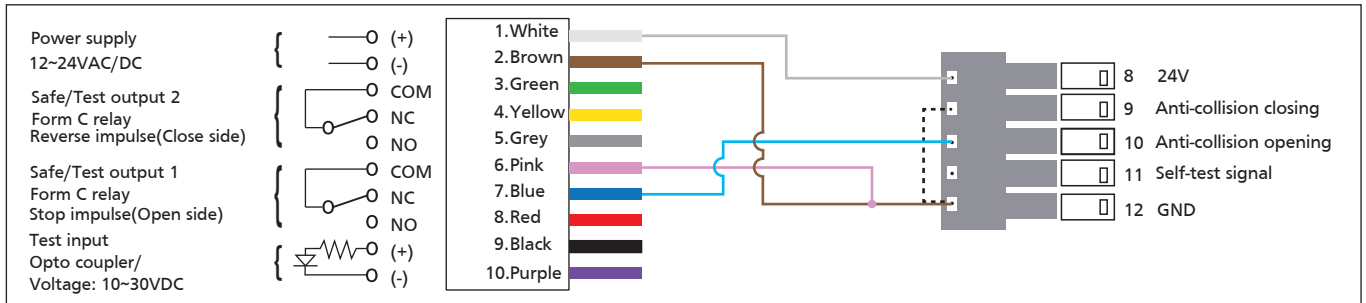

Note: When only connect top scan sensor on opening side have to short-circuit terminal 9 and 12, And Set Pn32 to 04

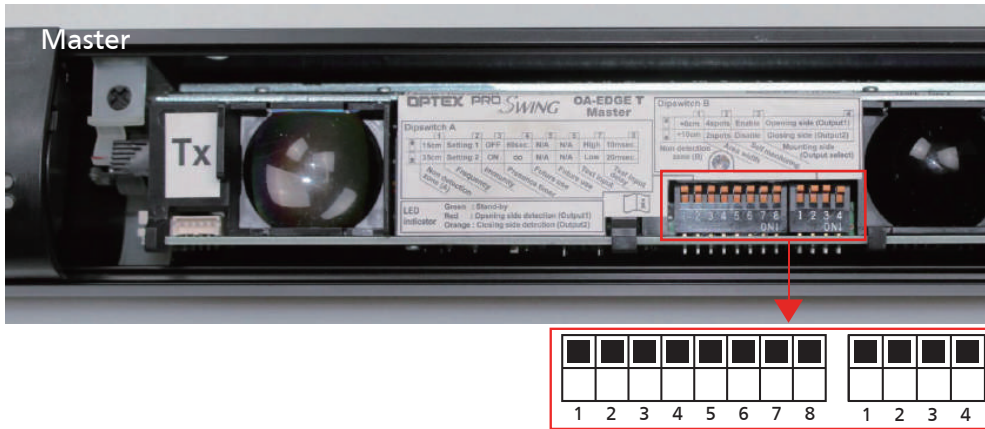

### 1.2 Closing side (AO.IRSS.700 Master)

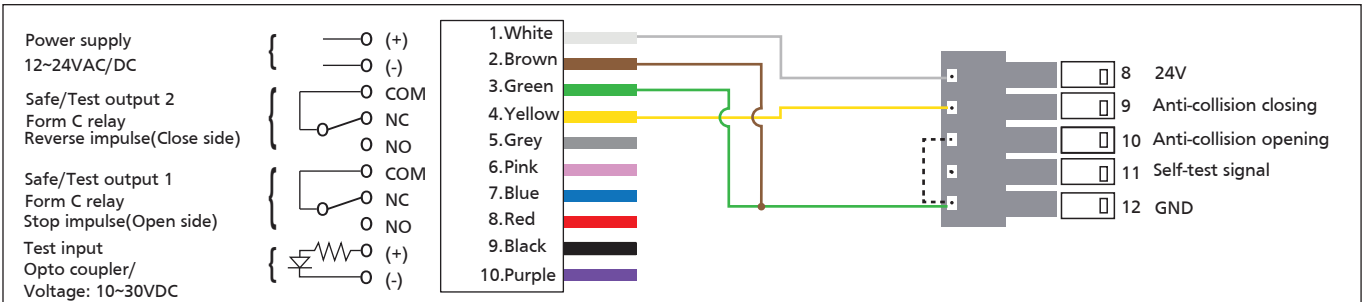

Note: When only connect top scan sensor on opening side have to short-circuit terminal 10 and 12, And Set Pn32 to 04

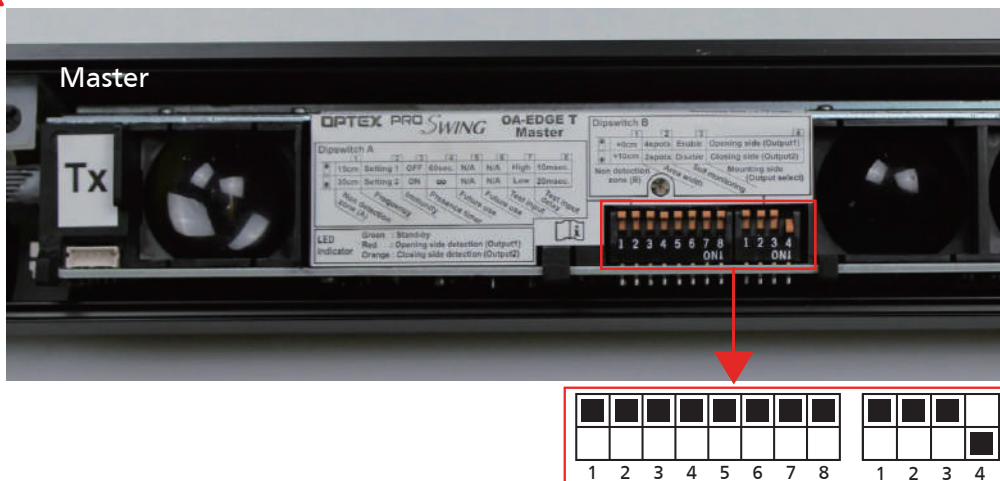

### 1.3 Opening and closing side (AO.IRSS.700 Master & AO.IRSS.700 Master)

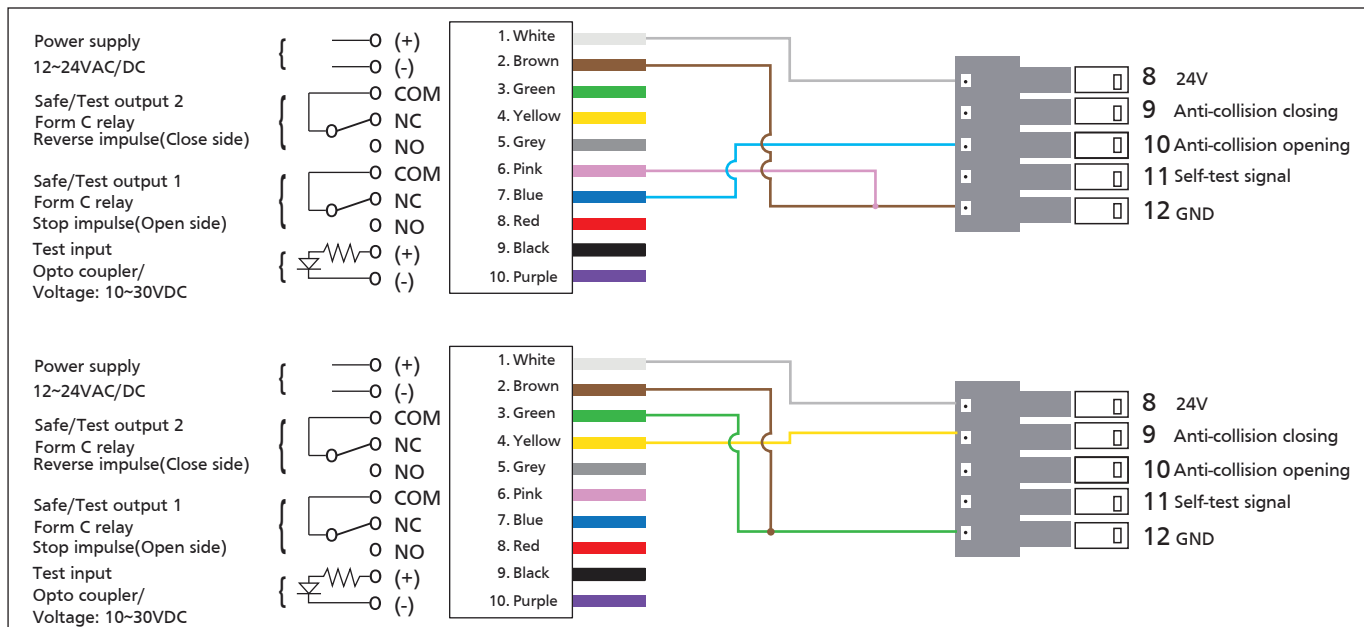

**!** Note: Set Pn32 to 04

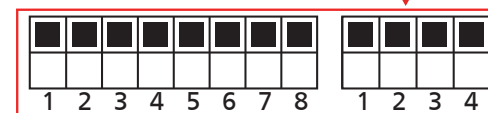
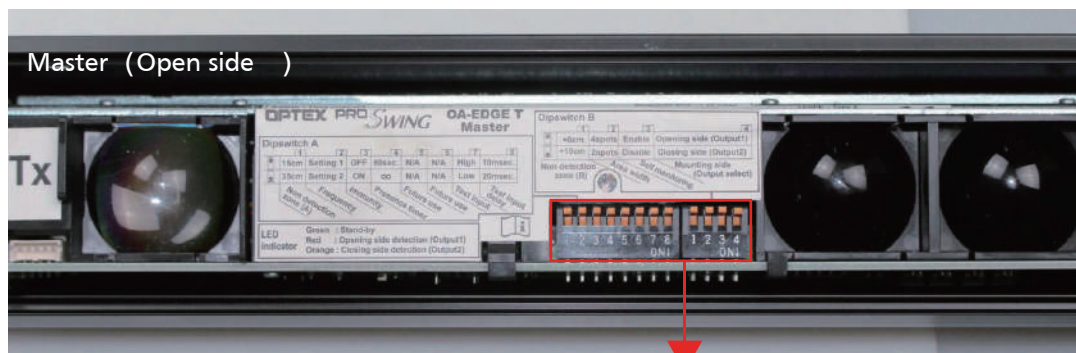
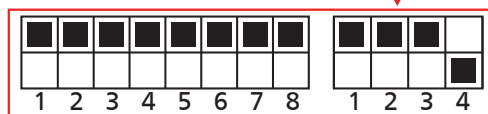
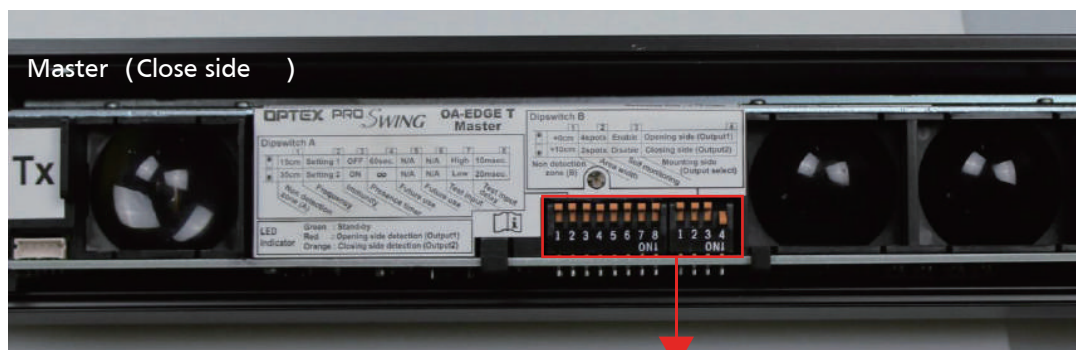

# Infrared Safety Top Scan Sensor

## 1.4 Opening and closing side (AO.IRSS.700 Master & AO.IRSS.700 Slave)

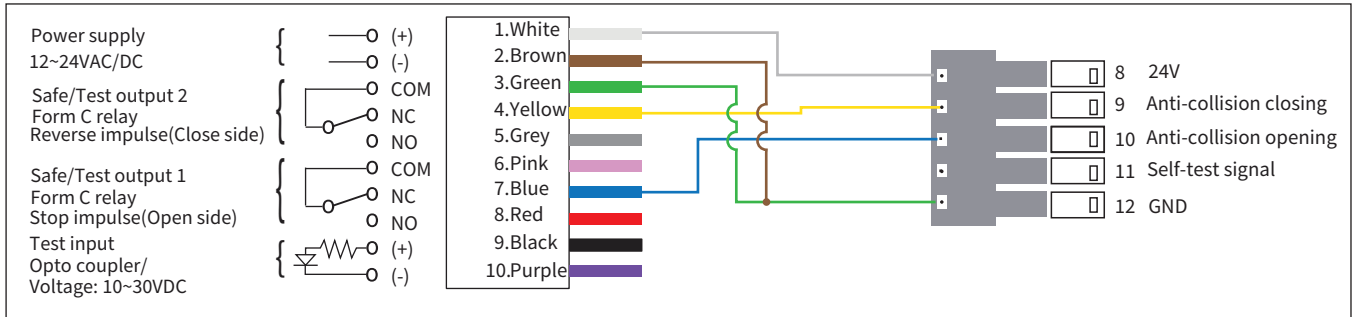

Note: Set Pn32 to 04

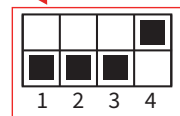
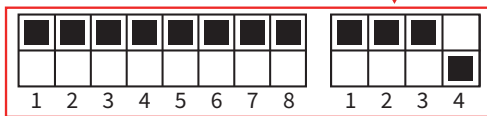
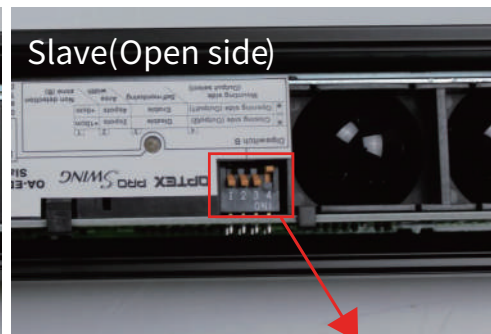
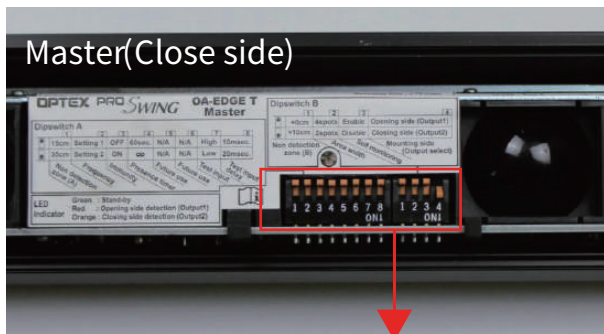

## 2. Turn on monitoring function

### 2.1 Opening side (AO.IRSS.700 Master)

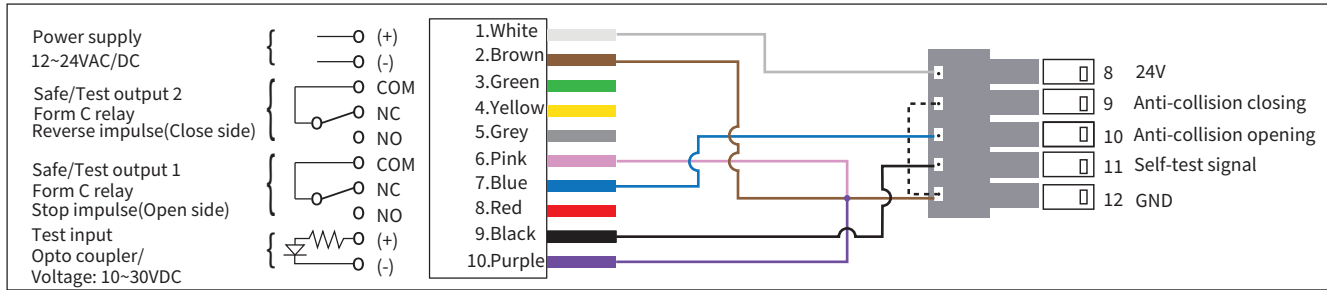

Note: When only connect top scan sensor on opening side have to short-circuit terminal 9 and 12, And Set Pn32 to 06

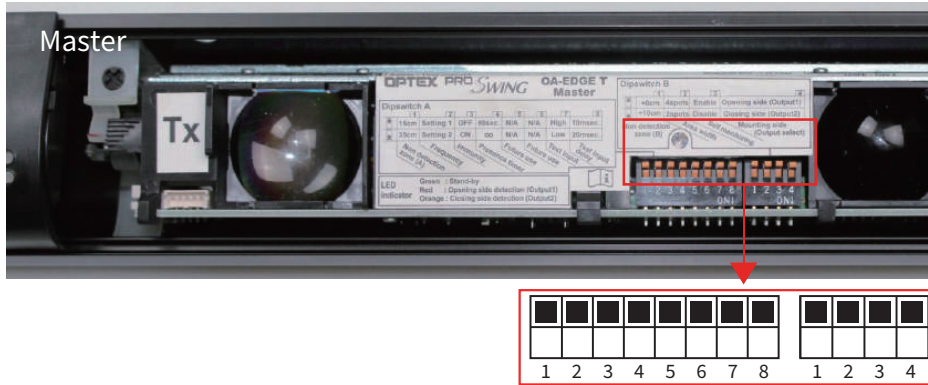

### 2.2 Closing side (AO.IRSS.700 Master)

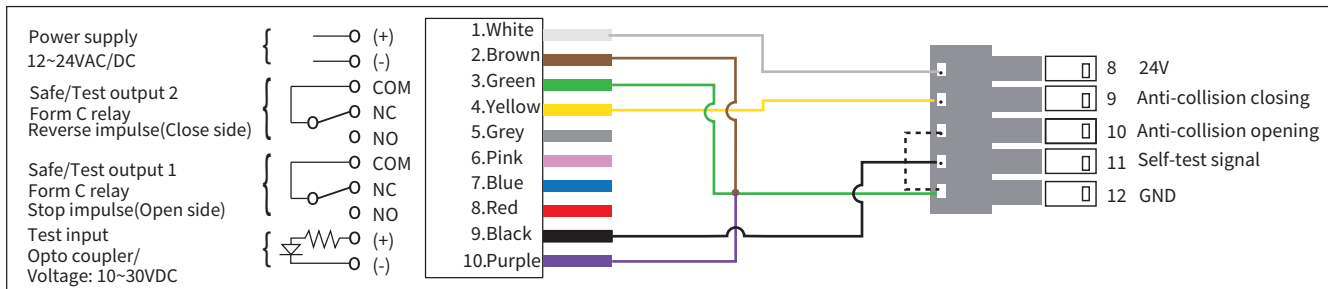

Note: When only connect top scan sensor on opening side have to short-circuit terminal 10 and 12, And Set Pn32 to 05

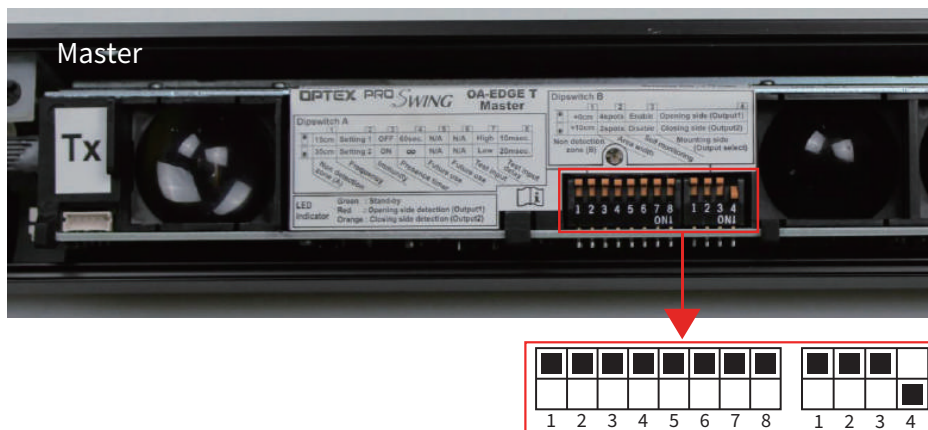

# Infrared Safety Top Scan Sensor

## 2.3 Opening and closing side (AO.IRSS.700 Master & AO.IRSS.700 Master)

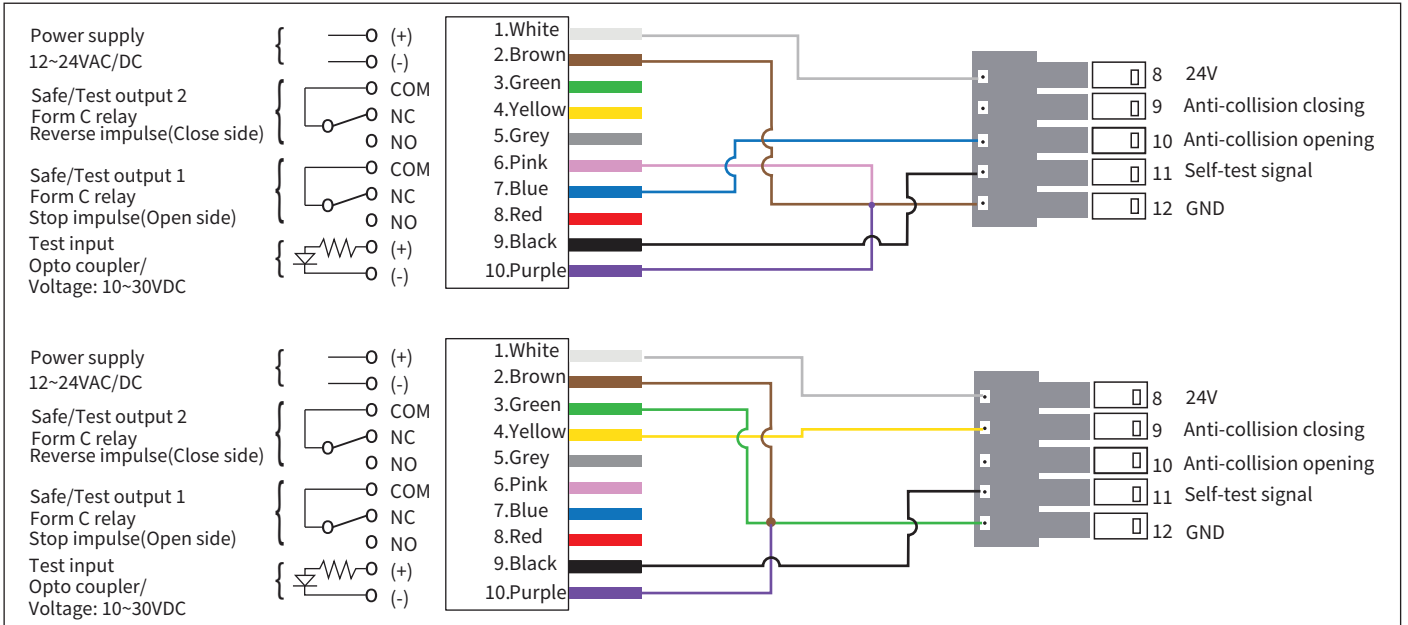

Note: Set Pn32 to 07

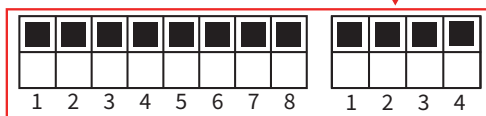
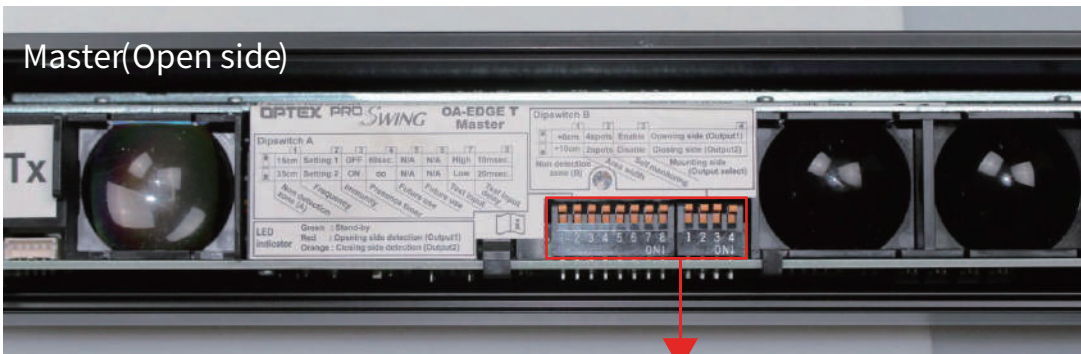
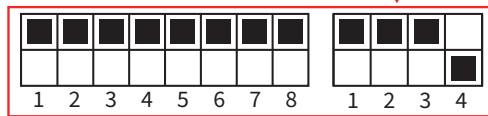
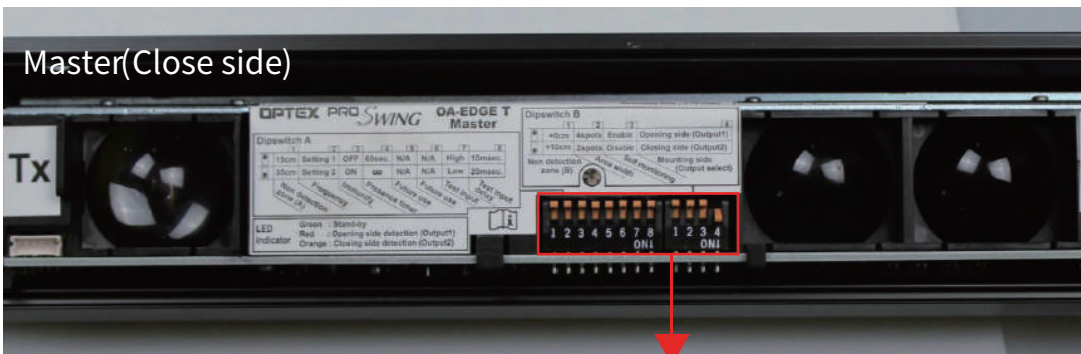

# Infrared Safety Top Scan Sensor

## 2.4 Opening and closing side (AO.IRSS.700 Master & AO.IRSS.700 Slave)

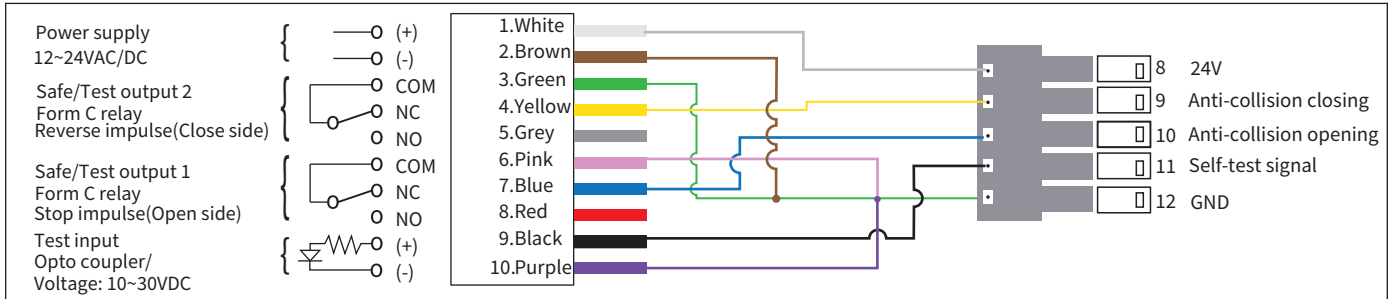

Note: Set Pn32 to 07

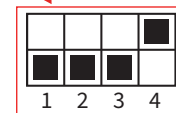
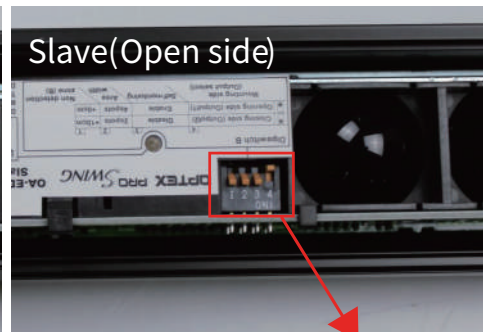
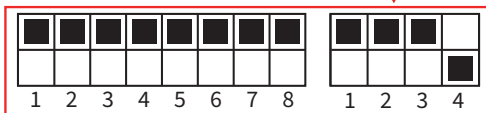
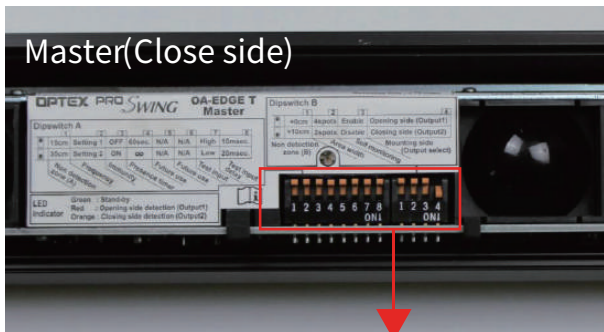

# Press Button/Remote/Functional Switch/Keypad

## Access keypad

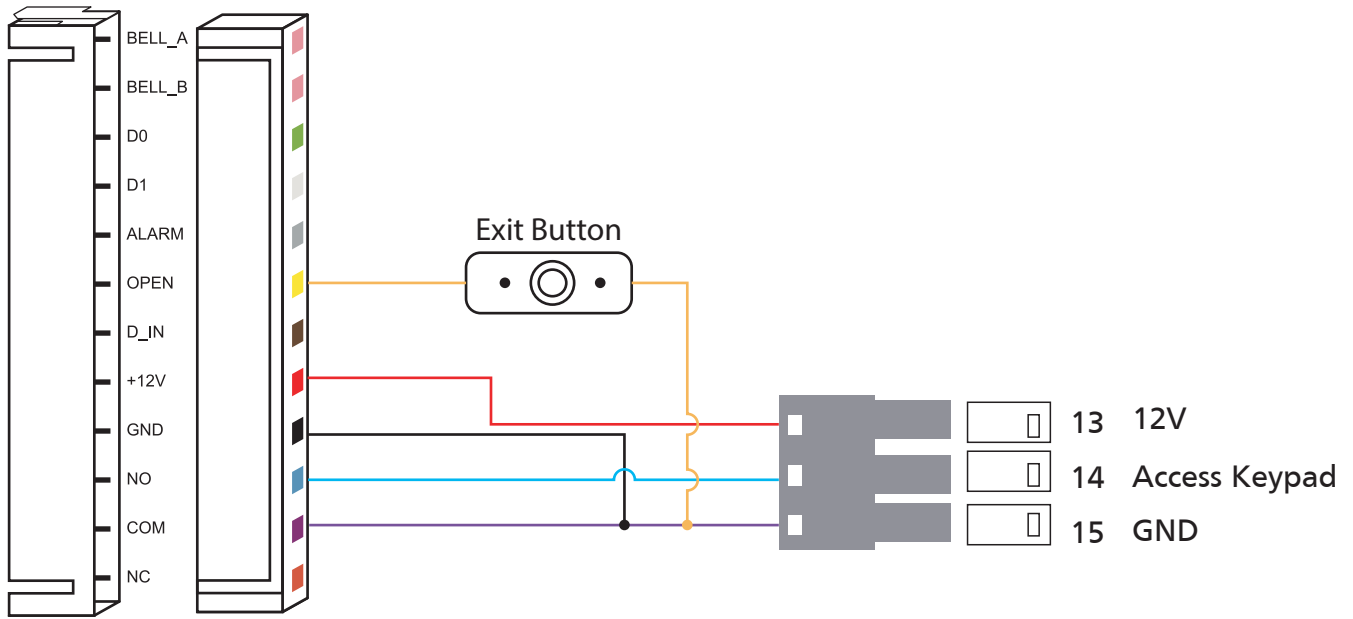

Note: Connecting the function keypad to the main door only.

## Function switch

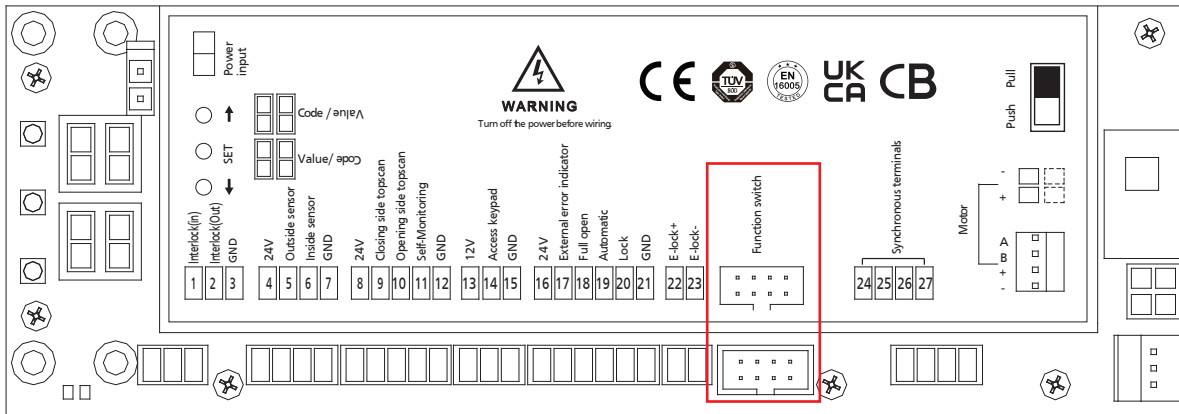
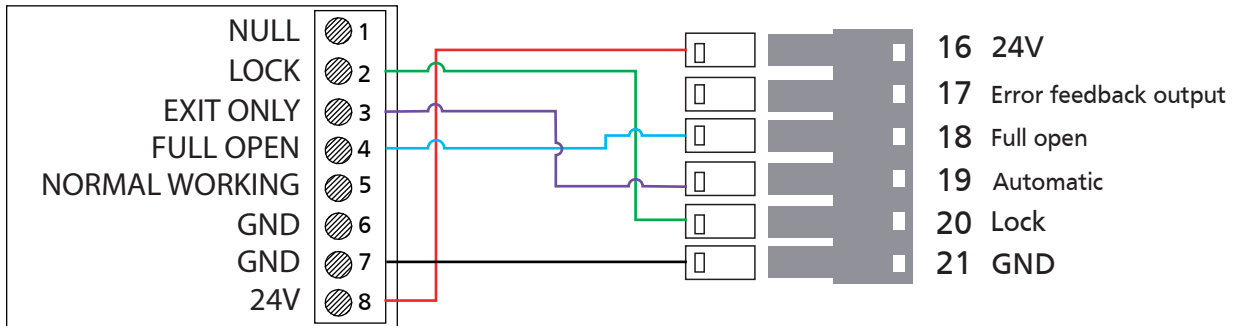

Note: Disconnect the Function switch cable from SW500 circuit board and switch to Auto/Co03 Mode (P.13)

Remote Button Instruction:

- A: Full Open - Door keep open
- B: Door close by closer spring force
- C: Door close by closer motor
- D: Lock - Door close and locked

# Data Setting

Data setting					
Code	Function	Setting range	Default	Description	
Pn00	Quit programing				
Pn01	LED upright display/ inverted display	00, 01	00		
Pn02	Opening speed(full energy mode)	12~52	40	Degree/s	
Pn03	Closing speed(full energy mode)	10~41	30	Degree/s	
Pn04	Opening speed(Low energy mode)	10~26	20	Degree/s	
Pn05	Closing speed(Low energy mode)	8~20	15	Degree/s	
Pn06	Braking opening angle	5-45	20	5 degree to 45 degree	
Pn07	Braking closing angle	5-45	10	5 degree to 45 degree	
Pn08	Full opening angle	45-105	90	45 degree to 105 degree	
Pn09	Hold-open time	0-30	3	1=1S	
Pn10	Starting delay time	0-7	4	1=0.3S (Single open: Starting delay time, Double open: Setting "Starting delay time" on Master door; Setting "Interval time between the opening of the two doors" on Slave door)	
Pn11	Locking delay time	0-7	4	1=0.3S	
Pn12	Locking type	00, 01	00	00: active to lock 01: automatic lock when closed	
Pn13	Push and go function	00, 01	00	00: not working; 01: working	
Pn14	Holding force(closed)	01-15	05	0-7.5KGS	
Pn15	Closing force	15-30	16	The force to keep the door closed when door open by wind.	
Pn16	Anti-clamp sensitivity when opening	02-37	10	1=0.04S	
Pn17	Anti-clamp sensitivity when closing	02-25	12	1=0.04S	
Pn18	Working mode	00-01	00	00:Full energy 01: Low energy	R:Change this data and restart the controller
Pn19	Opening force(Low energy mode)	11-32	18	2~8KG	
Pn20	Closing force(Low energy mode)	02-06	02	2~5KG	
Pn21	Opening force(Full energy mode)	18-40	35	4~18KG	
Pn22	Closing force(Full energy mode)	06-16	08	4~12KG	
Pn23	Wind stack mode (The motor working mode when door open by wind)	00, 01, 02	00	00: door closed and keep 2.5s, then motor stop working 01: door closed, then motor stop working immediately 02: close at the setting angle, then motor stop working	
Pn24	Limited angle(when the door open by wind and the opening angle is bigger then limited angle,motor will start to close door)	01-45	5	1=1 degree	
Pn25	Setting angle( the angle when door closing at this position the motor stop working)	01-20	2	1=1 degree	
Pn26	Wind stack mode	00, 01	00	00: not working; 01: working	R:Change this data and restart the controller
Pn27	Master/slave door	00-04	00	00: Auto learning(master) ; 01: Auto learning(salve) ; 03: master door; 04: slave door	
Pn28	The operating way at manual mode	00, 01	01	00: all terminals don't working 01: active to open, and close by spring	R:Change this data and restart the controller
Pn29	Toggle mode	00, 01	00	00: Active to open, then closing automatically 01: Active to open, active to close	Must connect to the "sensor"terminal
Pn30	Aux lock type	00, 03	00	00: Fail safe electronic lock 01: Fail secure electronic lock 02: Fail safe strike lock 03:Fail secure strike lock	R:Change this data and restart the controller
Pn31	Save the previous failure code	-	00	Save the previous failure code	
Pn32	Top scan setting	00-07	00	Check the details at Page 18	R:Change this data and restart the controller
Pn33	Top scan sensor, slow motion area in opening	45-106	106	To prevent an uncomplete opening cycle, the door can moving at low speed when the sensor detect the wall 00: Disabled 45-106: Adjustable 45 ° ~ 105 °, Turn this function on from the set opening angle	
Pn34	Interval time between the closing of the two doors (Setting on Master door)	00-15	05	1=0.12S	
Pn35	RESET	00, 01	00	Set Pn35=01, then go to default value	R:Change this data and restart the controller

# Status & Error Indicate

AO.SD3 with LED indicator design, Will show the status of operator, service people can know the trouble and status from indicator

No.	LED display	Description	Repairing suggestion	Remark
1	Fn00	Operator self-testing waiting the door stop working	Door leaf should close at the stop position by spring.	S
2	Fn01	Operator self-testing door leaf is at the stop position.	————	S
3	Fn99	Master mode	When Pn27=00 two operators have been connected	S RESET
4	F55	Slave mode	When Pn27=01 two operators have been connected	S RESET
5	F02	Operator is checking the closing position.	The process need 1~3s	S
6	Co01	Manual mode	————	RUN S
7	Co02	One way mode	————	RUN S
8	Co03	Automatic mode	————	RUN S
9	Co04	Lock mode	————	RUN S
10	Co05	Full open mode	————	RUN S
11	Pnxx	Code no	————	RUN S
12	=xx	value	————	RUN S
13	Er01	Encode or motor connection wrong	Check terminal J10	RESET
14	Er02	Motor not working or encode not connected	Check terminal J9	RESET
15	Er03	The closed position is wrong, or operator not start working at closed position.	1. Check whether the operator start working at closed position or not 2. Check the stopper is loosen or not.	RUN
16	Er04	Opening angle is more then 100degree	————	————
17	Er05	Master/slave setting wrong.	Check setting of Pn27	RESET
18	Er06	During one working circle, the encode can't detect full information.	Encode problem	————
19	Er07	During the first second when the power on, the motor doesn't work.	Encode broken or disconnect	————
20	Er08~Er09	For future	————	————
21	Er10	Operator self-testing for 20s and can't find closed position.	1. check whether the stopper is installed 2. Check the setting of switch push and pull bar.	RESET
22	Er11	Controller has problem.	Change a new controller.	RUN
23	Er16	Self-monition top scan can't finish self-testing.(closing way)	1. Check the connection of top scan. 2. Re-start the operator.	RUN
24	Er17	Self-monition top scan can't finish self-testing.(opening way)	1. Check the connection of top scan. 2. Re-start the operator.	RUN
25	Er18~Er99	For future	————	————

**RUN S:** State.

**RUN:** Check or change at working time.

**RESET:** The change value will be finished after re-start.

# Notes

A series of 25 horizontal dotted lines for writing notes.

# Notes

A series of 25 horizontal dotted lines for writing notes.

# Notes

A series of 25 horizontal dotted lines for writing notes.

# Enhancing **compliance** and **performance** at every door

Through our expert advice and support, we provide the peace of mind that full compliance is achieved and that life safety is assured.



**Head Office:**

Rutland Trading Co Ltd.  
Unit 4, Holmewood Business Park  
Chesterfield Road, Holmewood  
Chesterfield, S42 5US

**Contact us:**

+44 (0)1246 261491  
sales@rutlanduk.co.uk  
rutlanduk.co.uk